



ESTES INDUSTRIES
1295 H STREET
PENROSE, CO 81240 USA

FX
SERIES

GNOME
FLYING MODEL ROCKET KIT

#0886

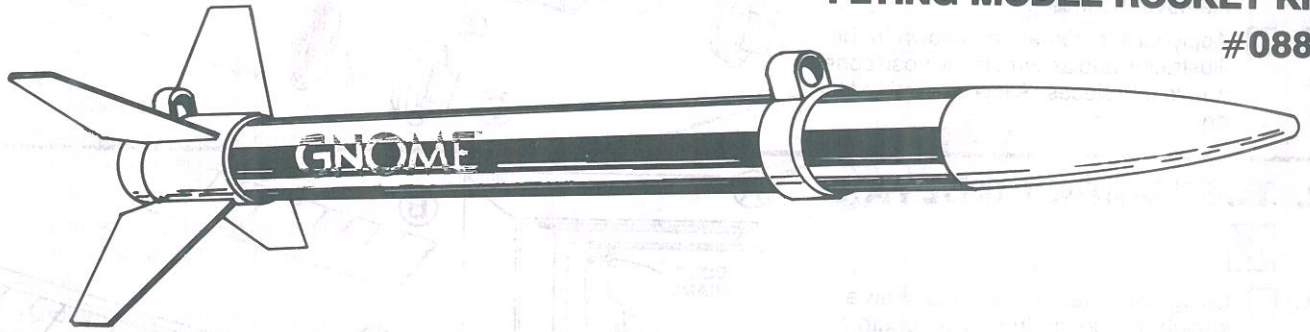

HOW TO USE THESE INSTRUCTIONS:

READ ALL INSTRUCTIONS BEFORE STARTING WORK ON THIS MODEL

- A. This rocket, incorporating basic model rocketry construction techniques, will help you in the development of your rocketry modeling skills.
- B. **Read each step first** and visualize the procedure thoroughly in your mind before starting construction.
- C. Lay parts out on the table in front of you. (Check inside tubes for any small parts.)
- D. Use exploded view to match all parts contained in kit.
- E. Collect all construction supplies that are not included in the kit.
- F. Test fit parts before applying any glue.
- G. The construction supplies required for each step are listed at the beginning of each step.
- H. Check off each step as you complete it.

EXPLODED VIEW

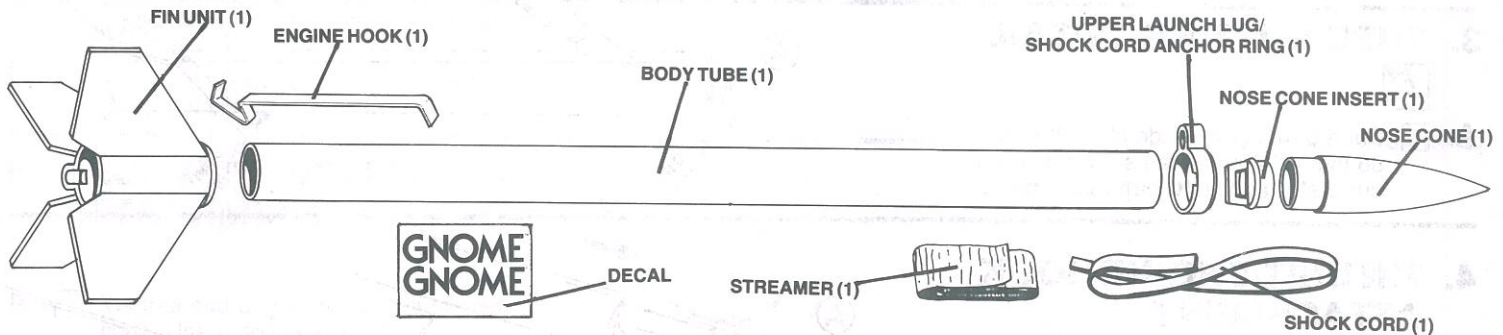

EXTREMELY IMPORTANT: THE EXPLODED VIEW IS FOR REFERENCE ONLY! DO NOT USE THIS DRAWING ALONE TO ASSEMBLE THIS MODEL.

The exploded view is only intended to assist you in locating the parts included in this kit. Refer back to this exploded view as you build your model step by step. This method will help you to put the parts into perspective as you progress through the construction.

CONSTRUCTION SUPPLIES

In addition to the parts included in your kit, you will need these construction supplies. Each step shows which supplies will be required.



SCISSORS



HOBBY KNIFE



PENCIL



PLASTIC CEMENT



MASKING TAPE

GLUE IS APPLIED TO SURFACES SHOWN IN RED.

1. NOSE CONE ASSEMBLY



- A. Test fit the nose cone insert into the nose cone. **Do not glue at this time.** Remove the insert.
- B. Apply plastic cement as shown in the illustration and assemble the nose cone and insert pieces. Allow assembly to dry.

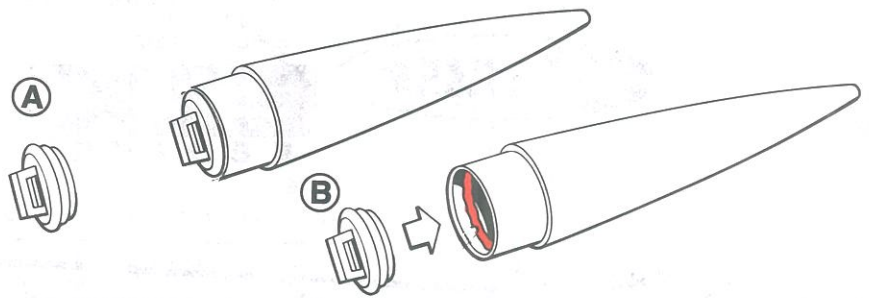

2. TUBE MARKING DETAIL



- A. Using a door frame as a guide, draw a straight line along the entire length of the tube.
- B. Locate the ruler printed in the center crease of this instruction sheet.
- C. Lay one end of the body tube on the zero mark of the ruler.
- D. Place three marks on the line you drew in step 2A. Make two marks 38 mm (1 1/2") from each end of the tube. Make a third mark at 10 mm (3/8") from zero. Make this mark 13 mm (1/2") long.

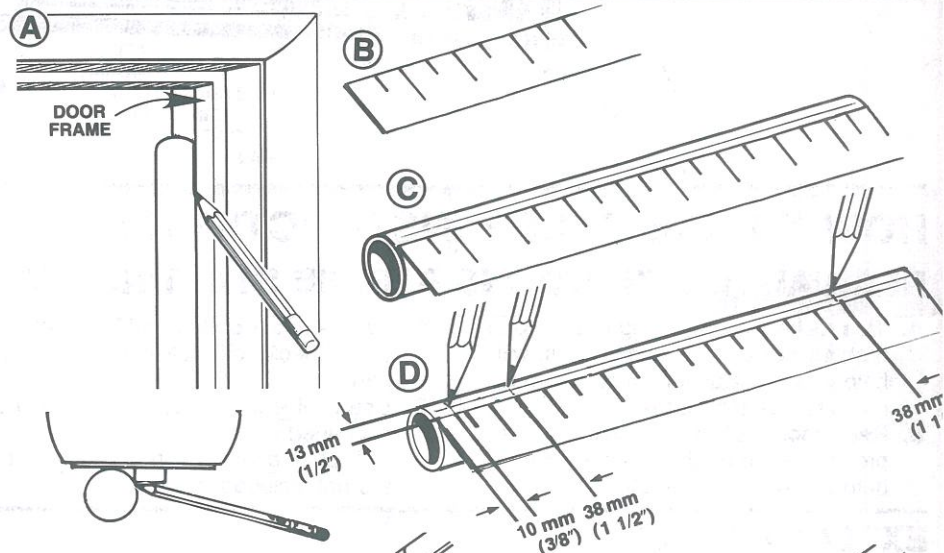

3. TUBE CUTTING DETAIL



- A. Cut a 3 mm (1/8") wide slit at the two 38 mm (1 1/2") marks as shown. **Do not cut a slot at the 10 mm (3/8") mark.**

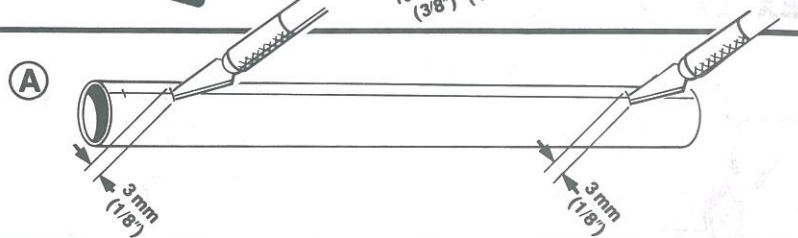

4. FIN UNIT/ENGINE HOOK ATTACHMENT



NOTE: Inspect the fin unit for the launch lug and engine hook slot.

- A. Slide the fin unit onto the body tube and position it about halfway along the tube. Orient the engine hook slot over the line you drew in step 2A.
- B. Insert one end of the engine hook into the slit on the end of the tube with the 10 mm (3/8") mark as shown.
- C. Test fit by sliding fin unit over the engine hook.
- D. Make sure hook fits into slot on fin unit.
- E. Slide fin unit halfway up tube.
- F. Apply tube-type plastic cement around the body tube in a "zigzag" fashion as shown in the illustration.
- G. Push the fin unit down the tube and over the engine hook. Continue pushing until the rear of the fin unit touches the 10 mm (3/8") mark. Carefully wipe away any excess plastic cement.

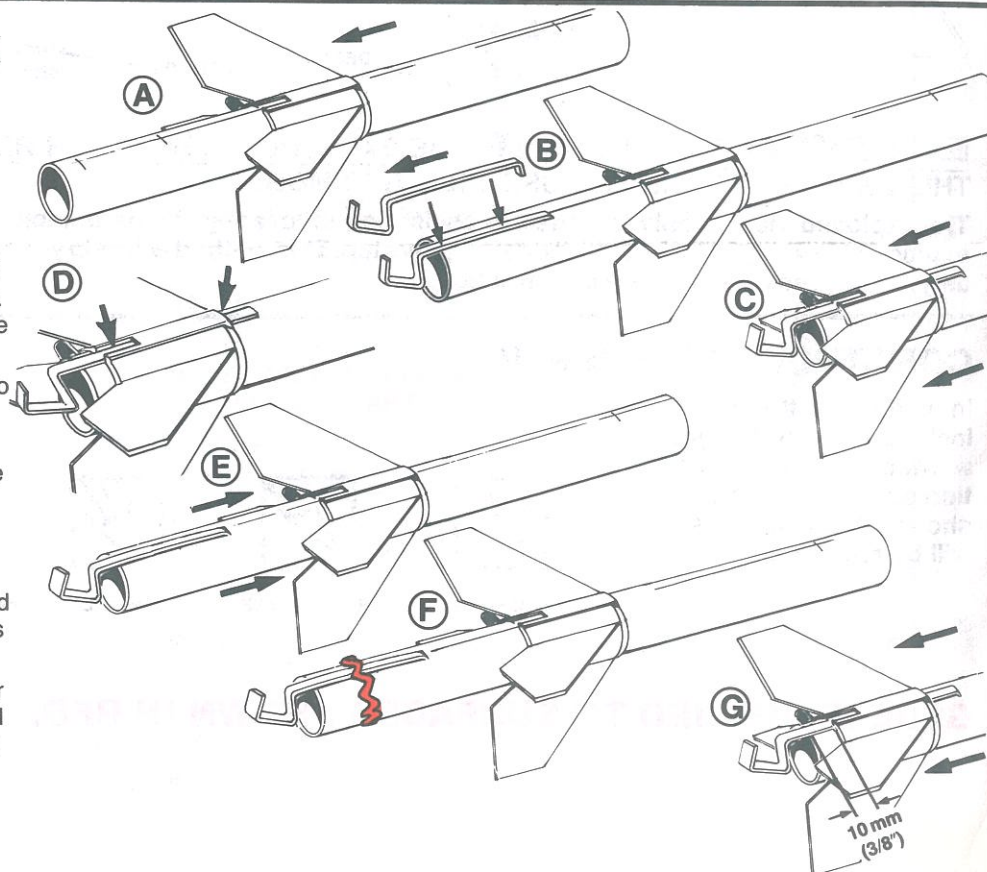

5. SHOCK CORD MOUNT ATTACHMENT



NOTE: The shock cord mount ring performs two functions.

1. It holds the shock cord in place.
 2. Acts as the forward launch lug.
- The forward launch lug must be in line with the fin unit launch lug for proper fit on the launch rod.

- A. Inspect the launch lug ring for the shock cord slot and launch lug using the illustration to the right.
- B. Use a modeling knife or pencil to push one end of the shock cord into the forward slot.
- C. Pull the shock cord through the slot and out the forward end of the body tube leaving 6 mm (1/4") exposed as shown.
- D. Test fit the launch lug ring by sliding it over the front of the tube. Orient the slot over the line as you did with fin unit and push over the shock cord.
- E. Make sure the cord fits into the slot on the inside of the ring. Now remove ring.
- F. Spread a band of plastic cement around the body tube just behind the protruding shock cord.
- G. Position the launch lug ring on the body tube noting the shock cord slot. Push the ring over the shock cord until the **forward edge** of the ring is even with the shock cord slot.
- H. Erase pencil line on body tube with pencil eraser.

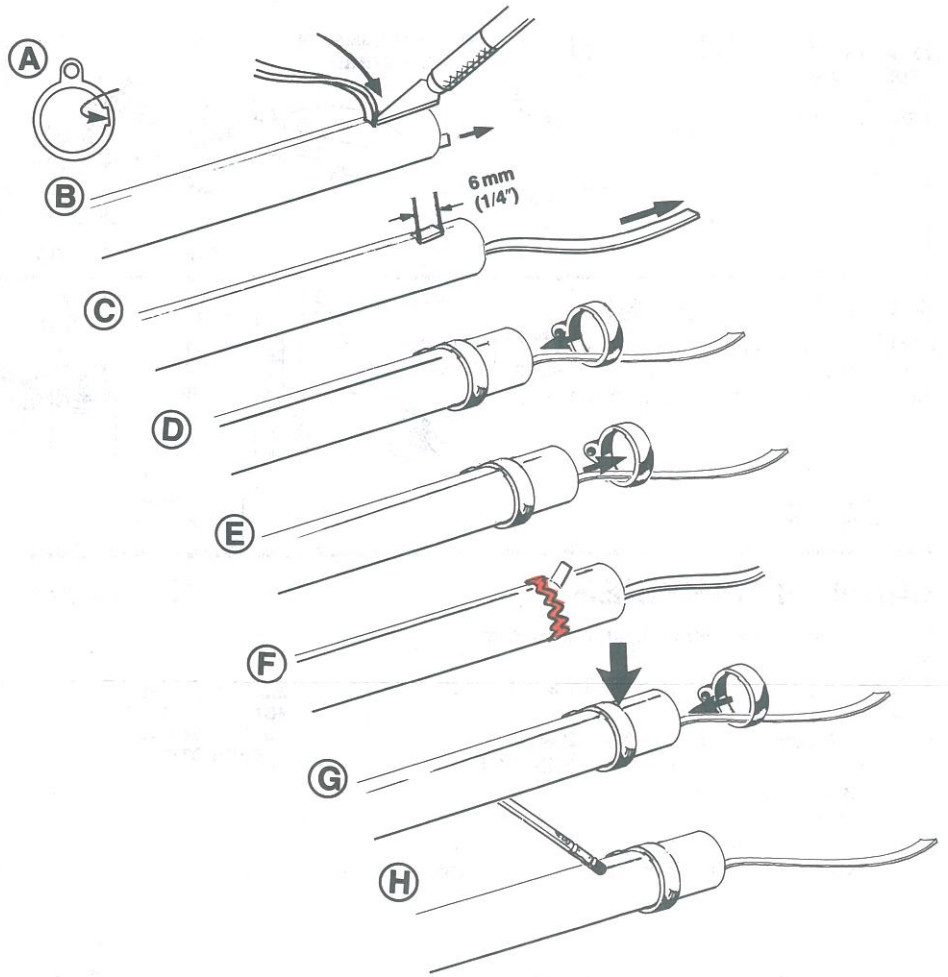

6. RECOVERY DEVICE ATTACHMENT

- A. Tie free end of the shock cord to nose cone. Use a double knot.
- B. Cut a 25 mm (1") long piece of 19 mm (3/4") wide masking tape.
- C. Lay end of shock cord over end of streamer material as shown and tape shock and streamer together.
- D. Press tape down firmly to assure a strong bond.
- E. Roll streamer, insert streamer, shock cord and nose cone into Gnome™ body. Recovery device should slide easily into body tube. If too tight, unfold and repack.

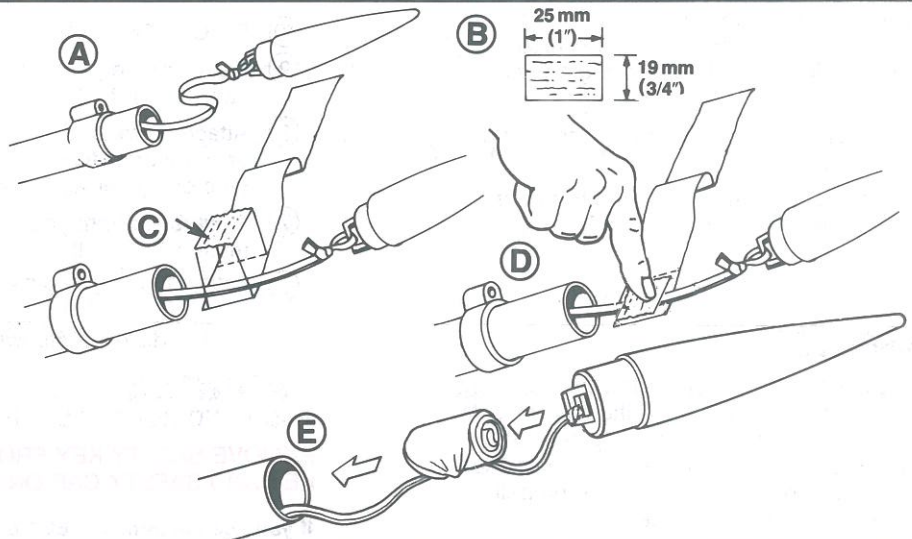

7. FINISHING YOUR ROCKET

When all glue is completely dry, apply self-adhesive decals. Cut out each decal inside dashed line, apply on model and press down.

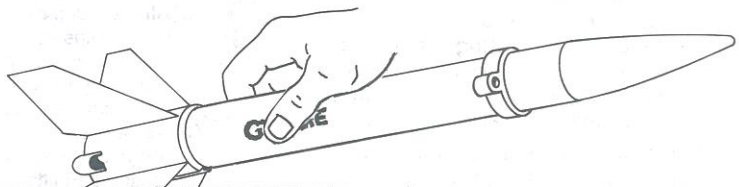

WHAT TO EXPECT WHEN FLYING YOUR GNOME™ ROCKET

The Gnome™ is easy to build and fly. The streamer recovery allows for safe recovery on small fields. With the largest engine you can use with the Gnome, the A3-4T, you can expect about 244 meters

(800 feet) in altitude. The 1/2A3-2T should deliver about 122 meters (400 feet). The A3-4T will work fine on football fields while the 1/2A3-4T would be perfect for baseball fields.

ROCKET PREFLIGHT

CRUMPLE AND INSERT
3 SQUARES OF
RECOVERY WADDING



FOLD STREAMER IN
HALF 2 TIMES

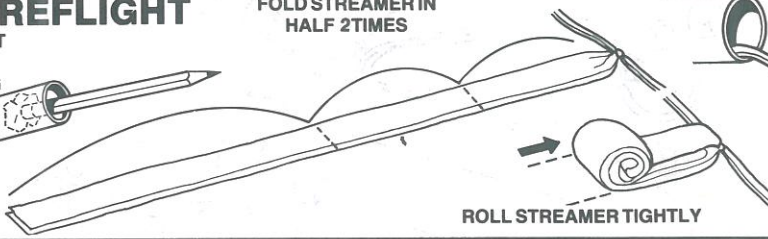

ROLL STREAMER TIGHTLY

INSERT STREAMER, SHOCK
CORD AND NOSE CONE
INTO ROCKET BODY

Recovery device should
slide easily into body
tube. If too tight, unfold
and repack again.

PREPARE ENGINE

NOTE: Igniter plugs come with rocket engines.
If your engines did not come with plugs, follow
the instructions that came with the engines.



SEPARATE IGNITER AND
IGNITER PLUG



HOLD ENGINE UPRIGHT,
DROP IN IGNITER



IGNITER
MUST
TOUCH
PROPELLANT



INSERT
IGNITER
PLUG

FIRMLY PUSH
ALL THE WAY IN



BEND
IGNITER
WIRES BACK



INSERT
ENGINE INTO
ROCKET

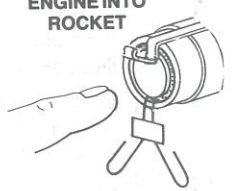

LAUNCH SUPPLIES

To launch your rocket you will need the following
items:

- Estes Electrical Launch Controller and Launch Pad
- Estes Recovery Wadding No. 2274
- Recommended Estes Engines: 1/2A3-2T, 4T, A3-4T or A10-3T

To become familiar with your rocket's flight
pattern, use a 1/2A3-2T engine for your first flight.
Use only Estes products to launch this rocket.

MICRO-CLIPS MUST
NOT TOUCH BLAST
DEFLECTOR OR
EACH OTHER

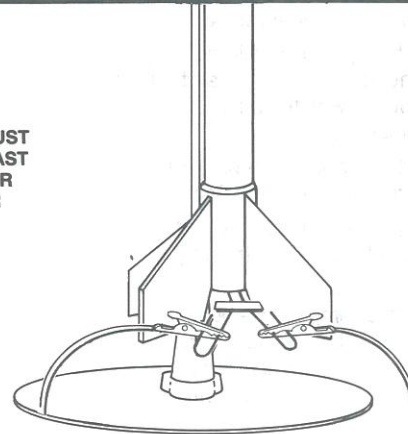

**SAFETY KEY MUST
NOT BE IN LAUNCH
CONTROLLER
WHEN ATTACHING
MICRO-CLIPS TO
ENGINE IGNITERS**

FLYING YOUR ROCKET

Choose a large field away from power lines, tall
trees, and low flying aircraft. Try to find a field at
least 76 meters (250 feet) square. The larger the
launch area, the better your chance of recovering
your rocket. Football fields and playgrounds are
great.

Launch area must be free of dry weeds and
brown grass.

Launch only during calm weather with little or no
wind and good visibility.

MISFIRES

If the igniter functions properly but the propellant
does not ignite, keep in mind the following: An
Estes igniter will function properly even if the
coated tip is chipped. However, if the coated tip
is not in direct contact with the engine propellant,
it will only heat and not ignite the engine.

When an ignition failure occurs, remove the
safety key from the launch control system and
wait one minute before approaching the rocket.
Remove the expended igniter from the engine
and install a new one. Be certain the coated tip
is in direct contact with the engine propellant,
then reinstall the igniter plug as illustrated above.
Repeat the countdown and launch procedure.

COUNTDOWN AND LAUNCH

- 10 BE CERTAIN SAFETY KEY IS NOT IN LAUNCH CONTROLLER.
- 9 Remove safety cap and slide launch lug over launch rod to place rocket on launch pad. Make sure the rocket slides freely on the launch rod.
- 8 Attach micro-clips to the igniter wires. Arrange the clips so they do not touch each other or the metal blast deflector. Attach clips as close to protective tape on igniter as possible.
- 7 Move back from your rocket as far as launch wire will permit (at least 5 meters - 15 feet).
- 6 INSERT SAFETY KEY to arm the launch controller.

Give audible countdown 5...4...3...2...1

LAUNCH!!

PUSH AND HOLD LAUNCH BUTTON UNTIL ENGINE IGNITES

REMOVE SAFETY KEY FROM LAUNCH CONTROLLER. REPLACE SAFETY KEY AND SAFETY CAP ON LAUNCH ROD.

If you use the ultrasafe E2™ or Command™ Launch Controllers to fly your models, use the following launch steps:

- After attaching micro-clips, etc., insert the safety key into the controller receptacle. If the igniter clips have been attached properly to the igniter, the red L.E.D. will now begin to flash on and off and the audio continuity indicator will beep on and off.
- Hold the yellow (left) arm button down. The L.E.D. will stop flashing and the audio indicator will produce a steady tone.
- Verbally count down from five to zero loud enough for the bystanders to hear. Still holding the yellow arm button down, push and hold the orange (right) button down until the rocket ignites and lifts off.

FOR YOUR SAFETY AND ENJOYMENT

Always follow the NAR* MODEL ROCKETRY SAFETY CODE while participating in any model rocketry activities.