

Miss **GEICO®**

29

**Owners Manual • Bedienungsanleitung
Manuel de l'utilisateur • Manuale dell'utente**

PRB4100B

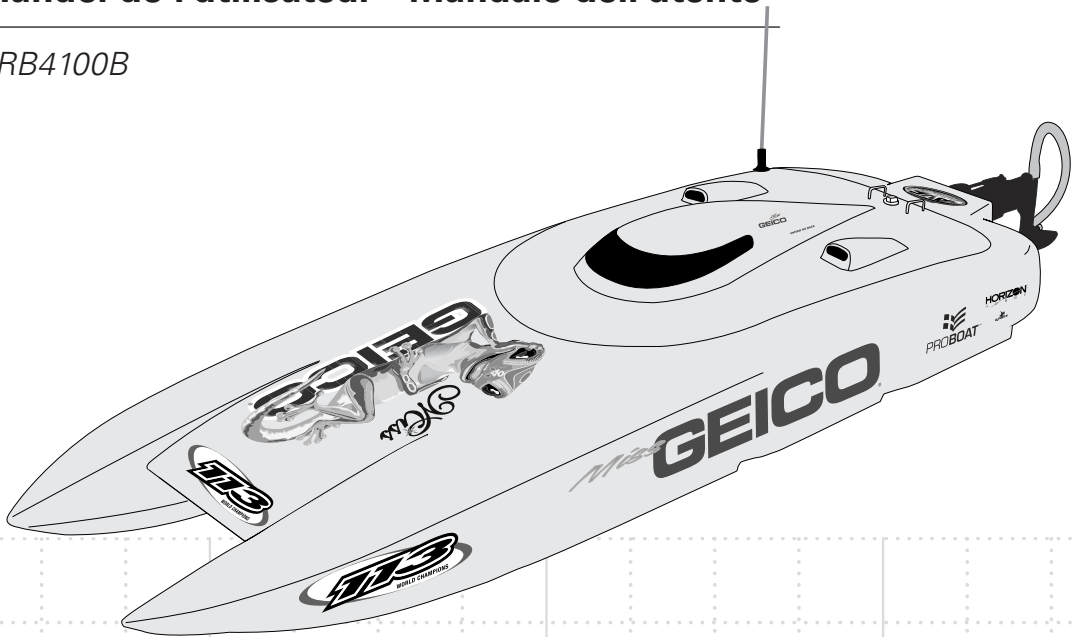

NOTICE

All instructions, warranties and other collateral documents are subject to change at the sole discretion of Horizon Hobby, Inc. For up-to-date product literature, visit www.horizonhobby.com and click on the support tab for this product.

MEANING OF SPECIAL LANGUAGE

The following terms are used throughout the product literature to indicate various levels of potential harm when operating this product:

NOTICE: Procedures, which if not properly followed, create a possibility of physical property damage AND little or no possibility of injury.

CAUTION: Procedures, which if not properly followed, create the probability of physical property damage AND a possibility of serious injury.

WARNING: Procedures, which if not properly followed, create the probability of property damage, collateral damage, and serious injury OR create a high probability of superficial injury.



WARNING: Read the ENTIRE instruction manual to become familiar with the features of the product before operating. Failure to operate the product correctly can result in damage to the product, personal property and cause serious injury.

This is a sophisticated hobby product and NOT a toy. It must be operated with caution and common sense and requires some basic mechanical ability. Failure to operate this Product in a safe and responsible manner could result in injury or damage to the product or other property. This product is not intended for use by children without direct adult supervision. Do not attempt disassembly, use with incompatible components or augment product in any way without the approval of Horizon Hobby, Inc. This manual contains instructions for safety, operation and maintenance. It is essential to read and follow all the instructions and warnings in the manual, prior to assembly, setup or use, in order to operate correctly and avoid damage or serious injury.

Safety Precautions and Warnings

As the user of this product, you are solely responsible for operating in a manner that does not endanger yourself and others or result in damage to the product or the property of others.

- When handling and/or transporting your boat, always pick up the boat from the front, keeping all moving parts pointed away from you.
- Always keep a safe distance in all directions around your model to avoid collisions or injury. This model is controlled by a radio signal subject to interference from many sources outside your control. Interference can cause momentary loss of control.
- Always operate your model in open spaces away from full-size vehicles, traffic and people.

- Always carefully follow the directions and warnings for this and any optional support equipment (chargers, rechargeable battery packs, etc.).
- Always keep all chemicals, small parts and anything electrical out of the reach of children.
- Always avoid water exposure to all equipment not specifically designed and protected for this purpose. Moisture causes damage to unprotected electronics.
- Never place any portion of the model in your mouth as it could cause serious injury or even death.
- Never operate your model with low transmitter batteries.

Age Recommendation: Not for children under 14 years. This is not a toy.

Table of Contents

Introduction	3	Boating Tips	7
Recommended Tools and Materials.....	3	Motor Care.....	8
Product Inspection.....	3	When you are Finished	8
Contents	3	Maintenance	8
Specifications.....	3	Checklists	9
Battery Safety Precautions	3	Before Boating.....	9
Boat Battery Pack Installation	4	After Boating.....	9
Rudder Installation	4	Troubleshooting Guide	9
Antenna Tube Installation.....	4	Limited Warranty.....	11
Decal Application	4	Parts Contact Information	12
Transmitter Battery Installation	5	Contact Information	12
Transmitter Controls.....	5	FCC Information.....	13
Getting Started	6	Compliance Information for the European Union....	13
Checking the Radio System.....	6	Identification of Components.....	53
Binding.....	7	Replacement Parts.....	53
Testing your Boat in the Water	7	Optional Parts	54

Introduction

Pro Boat® RC models look as good as they perform. Our boats, which include everything from scale sailboats to fully licensed powerboats, exceed expectations and provide years of radio control fun and excitement. Whether your passion leads you towards the pure serenity of sailing or the all-out speed of a Deep-V, Pro Boat models fit your taste, budget and lifestyle. You can count on us to be available any time you need help—the brand is backed by Horizon Hobby, one of the world's largest distributor of hobby-grade RC products. The Pro Boat brand will help you turn your boating passion into a reality, whether you're new to the hobby or an old pro. Please read this manual for operation and maintenance instructions.

Register your boat online at www.proboatmodels.com.

Recommended Tools and Materials

- Needle nose pliers
- Paper towel
- Rubbing alcohol
- Open-end wrench: 10mm (2)
- Nut driver: 8mm
- Phillips screwdriver: #1
- Hex wrench: 2.5mm, 3mm
- Clear tape (PRB0102)
- Pro Boat® Marine Grease and Gun (PRB0100)
- Li-Po battery (DYNP4000EC) or Ni-MH Battery (DYN1080EC) (2)
- Li-Po battery charger (DYN4066) or Prophet™ Sport AC/DC Peak Ni-MH Charger (DYN4056)

Product Inspection

Carefully remove the boat and radio transmitter from the box. Inspect the boat for damage. If you find damage is present, please contact the hobby shop where you purchased your boat or the nearest Horizon Hobby service center.

Contents

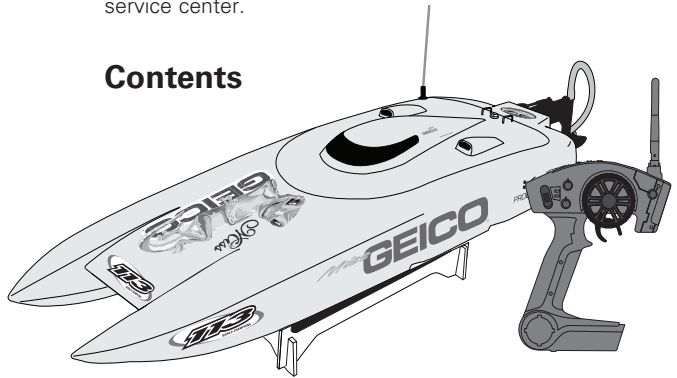

Specifications

Length	30 in (762mm)	Receiver	Spektrum™ MR200	Tip: 4 AA batteries (sold separately) are required to operate the transmitter. A Li-Po battery (DYNP4000EC) or Ni-MH Battery (DYN1080EC) (sold separately) is required to operate this boat.
Beam	11 in (279mm mm)	Hull Material	Fiberglass Composite	
Transmitter	Spektrum 2.4GHz Pistol Grip Transmitter (DX2E)	Motor	1500Kv	
		ESC	60-amp brushless, water-cooled	

Assembling the Boat Stand

1. Attach the side stand pieces to the end pieces as shown.
2. Use medium CA or epoxy adhesive to secure the side stand pieces to the ends.
3. Allow the adhesive to dry before placing your boat on the stand.

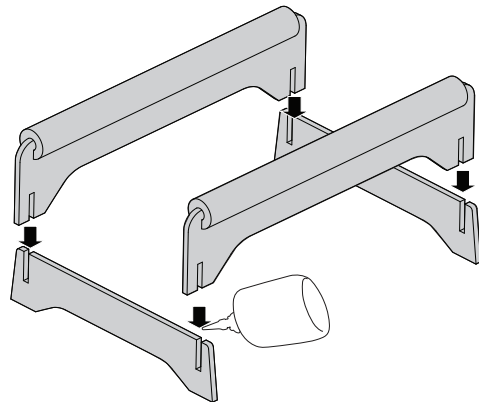

Battery Chemistry Switch

This switch allows the ESC to detect voltage. When the switch is in the OFF position, low voltage cutoff (LVC) is disabled. You will know you have reached LVC when the motor power decreases while the boat is in operation.

Li-Po: move the battery chemistry switch to the ON position

Ni-MH: move the battery chemistry switch to the OFF position.

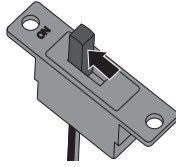

Tip: The ESC programming card (DYNAM3821, sold separately) allows the consumer to adjust low voltage cutoff and other ESC programming.

At the factory, the ESC is programmed at High Cutoff.

High Cutoff: The Ni-MH cutoff voltage is .9 volts per cell and the Li-Po cutoff is 3.3 volts per cell. High Cutoff allows ample power in reserve after cutoff for returning the boat to shore.

Low Cutoff: The Ni-MH cutoff voltage is .7 volts per cell and the Li-Po cutoff is 3.0 volts per cell. Low Cutoff allows longer run times, but leaves less power in reserve after cutoff for returning the boat to shore.

Battery Safety Precautions

- When using a Li-Po battery, always ensure the Battery Chemistry Switch is in the ON position.
- Never discharge a Li-Po battery below 3V per cell.
- Always disconnect a battery from the ESC when not in use.
- Avoid continually operating to LVC, as this could result in damage to the battery.

Installing the Battery Packs

1. Turn the latch so the tab is parallel with the back of the hull, then lift the hatch up and back from the hull.
2. Remove the radio box cover.
3. Install the included hook and loop tape on the battery packs. Install the battery on the hook and loop strips in the compartment.

Tip: Move the packs forward or back to adjust the center of gravity for your boat. Move the packs toward the bow so the bow rides lower in the water. Move the packs away from the bow so that the bow rides higher in the water.

4. Connect the battery pack to the ESC power connectors, as needed.
5. Disassemble in reverse order.

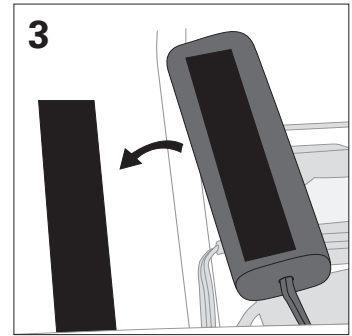
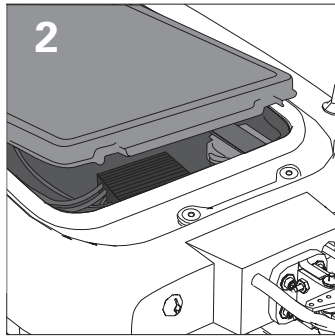
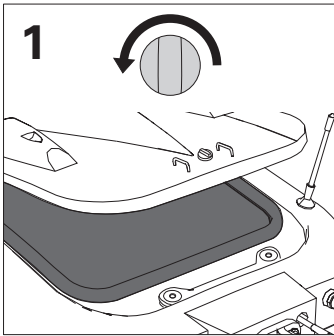

Antenna Tube Installation

1. Carefully feed the end of the receiver antenna through the grommet inside the hull.
2. Pull the antenna wire out of the grommet towards the outside of the boat, then slide the antenna through the antenna tube.
3. Insert the tube into the grommet, then fit the cap onto the tube.

4. Apply clear tape to the antenna, grommet and hull in the boat to keep the antenna from moving. The antenna must be installed above the boat's waterline to get the best reception of your transmitter's signal.

Arrange the shorter antenna in the hull at a right or near 90 degree angle to the antenna in the tube. Attach the antenna inside the hull, away from all electrical wiring and components, using clear tape.



Transmitter Battery Installation

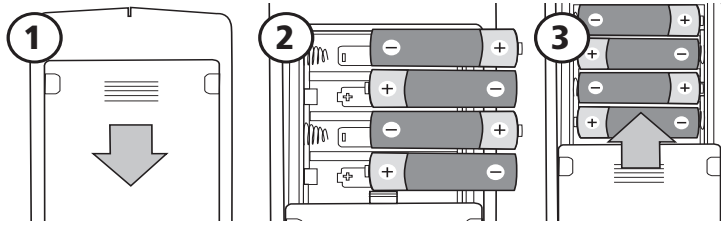

This transmitter requires 4 AA batteries.

1. Remove the battery cover from the transmitter.
2. Align the battery polarity with the markings in the compartment and install the batteries.
3. Install the battery cover.

Transmitter Controls

Reverse Switch

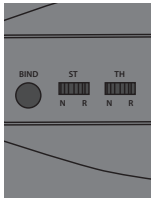

Allows you to change the direction of steering (ST. REV) and throttle (TH. REV) controls. Ensure proper function with a radio system test.

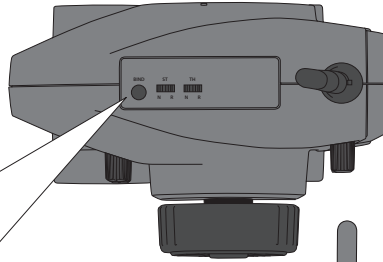

Steering Trim



Adjust to make the vehicle drive straight with no input at the steering wheel

Throttle Trim



Adjusts the neutral point of the electronic speed control

Steering Rate



Adjusts the amount the rudder moves when the steering wheel is turned left or right

Power Switch

Power on or off the transmitter

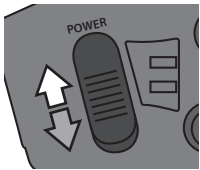

Steering Wheel



Controls steering. Right and Left steering with ST. REV Switch on N (See ST. REV switch)

Battery Level Indicator

- Solid Green: Battery voltage is good (Above 4V).
- Flashing Green: Battery voltage is critically low (below 4V). Replace batteries.

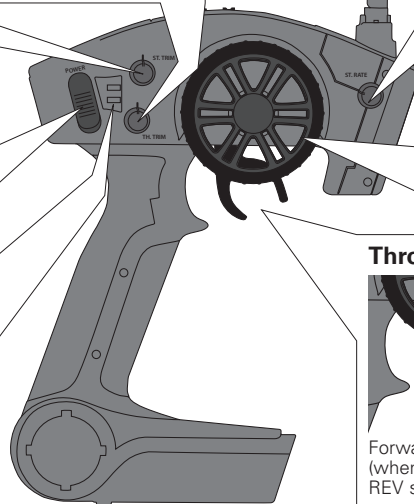

Throttle Trigger

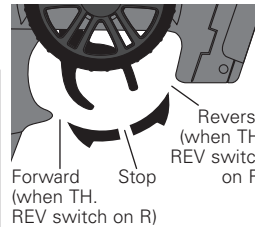

Controls power to the motor for forward or reverse (See TH. REV switch)

RF Mode

The DX2E has a France RF Mode that complies with French regulations. The DX2E must be in France mode when used outdoors in France. At all other times, the transmitter should be in Standard mode.

France mode

Turn the wheel full left, pull the trigger full throttle and hold down the bind button while turning on the transmitter. The Green LED will flash twice.

Standard mode

(Default preset set at factory)

Turn the wheel full right, pull the trigger full throttle and hold down the bind button while turning on the transmitter. The Green LED will flash once.

Getting Started

1. Power on the transmitter.
2. Turn ON the Li-Po battery switch (when using Li-Po batteries).
3. Connect the battery.
4. Power on the ESC switch.
5. Do a test of the transmitter's control of the boat with the boat on the display stand.
6. After launching the boat in the water, start driving slowly, and, if the boat does not go straight, adjust the steering trim dial on the transmitter.

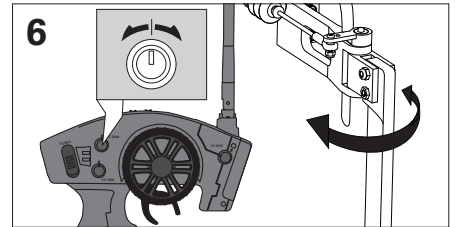
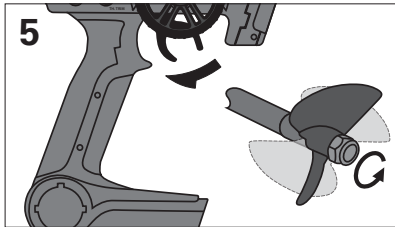
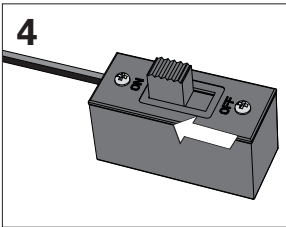
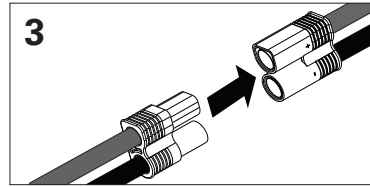
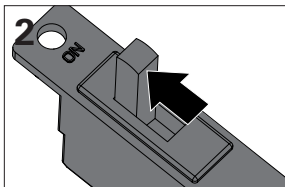
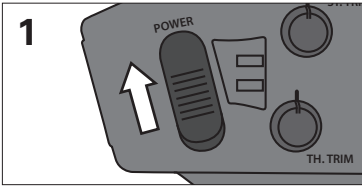

Checking the Radio System

CAUTION: Always keep all body parts, hair and dangling or loose items away from a spinning propeller, as these could become entangled.

NOTICE: Always power on the transmitter before powering on the ESC. Always power off the ESC before powering off the transmitter. Never transport the boat with the battery connected to the ESC.

1. Turn the transmitter throttle and steering trim knobs to the 10 o'clock position.

2. Power on the transmitter.
3. Connect a fully charged battery to the ESC.
4. Power on the ESC switch. The boat will beep 5 times.
5. Ensure the rudder moves in the proper direction when the steering wheel is moved left or right.
6. Pull the throttle to full, then return the throttle to neutral, ensuring the propeller turns counterclockwise.

The auto-sensing voltage cutoff will also engage when the ESC detects low battery charge. Release the throttle and recharge the battery.

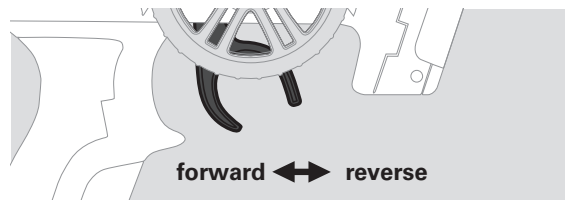
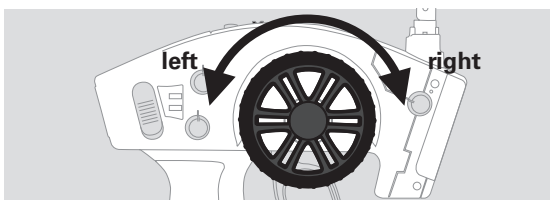

Failsafe

In the unlikely event that the radio connection is lost during use, the receiver will drive the servos to their preprogrammed failsafe positions (normally no throttle and straight steering). If the receiver is powered on before powering on the transmitter, the receiver will enter failsafe mode, driving the servos to their preset failsafe positions. When the transmitter is powered on, normal control is resumed. Failsafe servo positions are set during binding.

Binding

Binding is the process of programming the receiver to recognize the GUID (Globally Unique Identifier) code of a single specific transmitter. The DX2E and MR200 are bound at the factory. If you need to rebind, follow the instructions below.

1. With the receiver off, insert the bind plug into the BND/BAT port on the receiver.
2. When a battery is connected to the ESC and the ESC is connected to the throttle port on the receiver, power on the ESC switch. An LED on the receiver will flash rapidly, showing the receiver is in Bind mode.
3. Do not touch the throttle or steering controls, as this sets failsafe settings. The throttle and throttle trim should always be at the lowest setting during bind mode. Press and hold the bind button and power on the transmitter. The green LED on the front of the transmitter will flash within three seconds, indicating the transmitter is in bind mode.

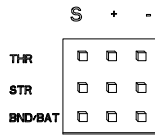

4. Release the bind button when the green LED flashes.

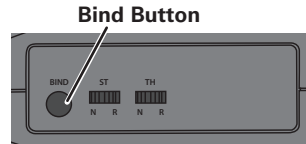

5. The receiver's LED will turn solid when the transmitter and receiver are bound.
6. Remove the bind plug and store it in a convenient place.

You must rebind when:

- Different failsafe positions are desired e.g., when throttle or steering reversing has been changed.
- Changing receiver types e.g., changing from a DSM[®] receiver to a DSM2[®] or Marine receiver.
- Binding the receiver to a different transmitter.

Testing Your Boat in the Water

1. Carefully place the boat in the water.
2. Operate the boat at slow speeds near the shoreline. Avoid objects in the water at all times. When the boat is moving forward, ensure water flows out of the coolant outlet. Remove any blockage from the rudder inlet and coolant system or the motor and ESC (electronic speed control) may overheat.
3. Once you are comfortable operating the boat at slow speeds, it is safe to operate the boat farther from the shore.

Tip: If you are using too much steering trim on your transmitter to make the boat drive straight, return the trim to neutral and mechanically center the rudder. To do this, loosen the ball link from the rudder horn, then turn the ball link on the linkage threads until the rudder is properly centered.

4. Bring the boat back to shore when you notice the boat starting to lose speed.
5. Power off the ESC and disconnect the battery packs.
6. Allow the motor, ESC and battery packs to cool before charging the batteries or operating the boat again.

NOTICE: Do not turn off the transmitter first or the receiver may pick up stray signals and run out of control.

Boating Tips

Avoid boating near other watercraft, stationary objects, waves, wakes and other rapidly moving water, wildlife, floating debris or overhanging trees. You should also be careful to avoid boating in areas where there are many people, such as swimming areas, park waterways or fishing areas. Consult local laws and ordinances before choosing a location to pilot your boat.

Maximum speeds are only achieved when the water conditions are smooth and there is little wind. A sharp turn, wind or waves can turn over a boat when it is moving quickly. Always pilot your boat for the wind and water conditions so that the boat does not turn over.

When running your boat for the first time, we recommend calm wind and water conditions so that you can learn how the boat responds to your control.

When making turns, decrease the throttle position in order to decrease speed and probability of flipping the boat over.

NOTICE: When running at full speed in choppy waters, the prop may exit and re-enter the water repeatedly and very quickly, subjecting the propeller to some stress. Frequent stress may damage the propeller.



CAUTION: Never retrieve your boat from the water in extreme temperatures, turbulence or without supervision.

Center of Gravity

Moving the batteries to the front or back of the compartment can significantly affect the boat's performance.

1. Move the batteries toward the rear of the boat to raise the front of the hull for increased speed.

2. Move the batteries toward the front of the boat for faster initial acceleration to eliminate oscillation or bouncing, and to increase stability.

Drive Height

Lowering the drive will increase the propeller's ability to bite at take off, but excessive lowering can cause the back of the boat to feel loose and decrease top end stability. Raising the drive helps eliminate oscillation or bouncing and assist with top end stability, but excessively raising the drive can reduce top speeds and cause cavitation. If the conditions are questionable, adjust the prop strut down a bit to reduce the likelihood of having the boat overturn. The motor mount is slotted to allow you to move the motor slightly when adjusting the propeller strut.

Loosen the motor mounting screws (A) when adjusting the propeller strut angle trim and retighten after adjustment is complete. Use a 3mm hex wrench and 7mm nut driver to loosen the bolt that attaches the output to the bracket to adjust the height. Raise or lower the prop strut. Tighten the bolt when adjustment is complete. You may also turn the dual rate dial down to reduce rudder travel in rough water conditions.

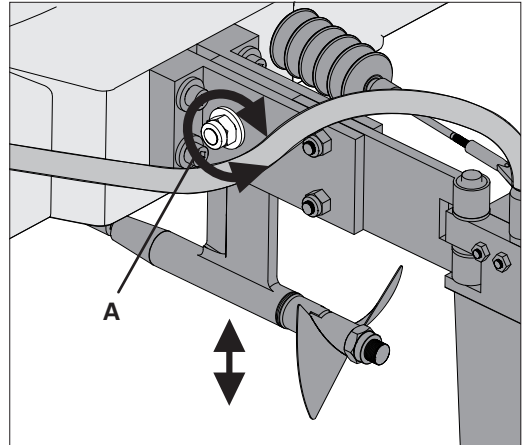

Motor Care

- Prolong motor life by preventing overheating conditions. Undue motor wear results from frequent turns, stops and starts, pushing objects, boating in rough water or vegetation and boating continuously at high speed.
- Over-temperature protection is installed on the ESC to prevent circuit damage, but cannot protect the motor from pushing against heavy resistance.

When You are Finished

1. Power off the ESC.
2. Disconnect the batteries.
3. Power off the transmitter.
4. Remove the batteries from the boat.

Tip: Always store the boat open (without the hatch and inner liner sealed) or moisture may cause mold and mildew to grow in the boat.

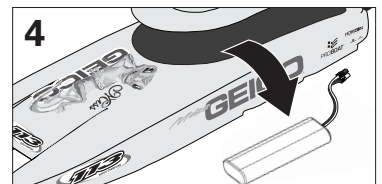
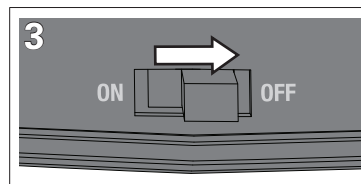
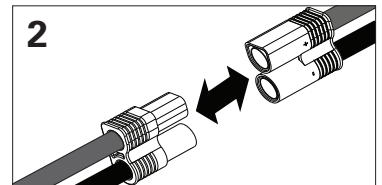
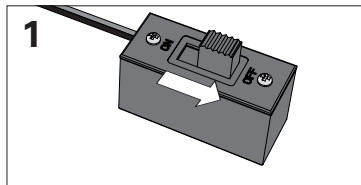

Maintenance

Always replace the flex shaft when it is damaged or shows visible wear or injury and property damage may result.

Lubricating the flex shaft is vital to the life of the drivetrain. The lubricant also acts as a water seal, keeping water from entering the hull through the stuffing box.

Lubricate the flex shaft, propeller shaft and all moving parts after every 2–3 hours of operation. Always replace any parts that show visible wear or damage.

1. In the hull, use tools to loosen the collet nut (A) from the flex shaft (B).

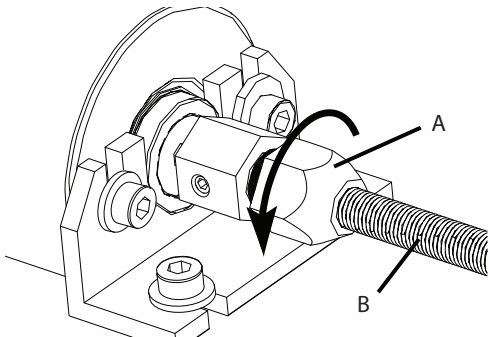

2. Turn the rudder (C) and remove the flex shaft from the stuffing box (D) and drive strut (E) at the rear of the boat.

Tip: Use paper or cloth to touch the flex shaft.

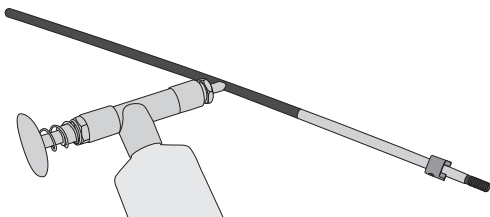

3. Wipe lubricant and material from the flex shaft. Lubricate the full length of the flex shaft assembly up to the drive dog using marine grease (PRB0101 or PRB0100). Also apply grease to the collet threads.

4. Carefully reinstall the flex shaft in the drive strut, stuffing box and collet. If the flex shaft is difficult to remove or install in the collet, use a flat screwdriver to spread the grips of the collet. Ensure there is a 1–2mm gap and a washer (F) between the drive strut and drive dog (G) to allow for flex shaft shrinkage under load

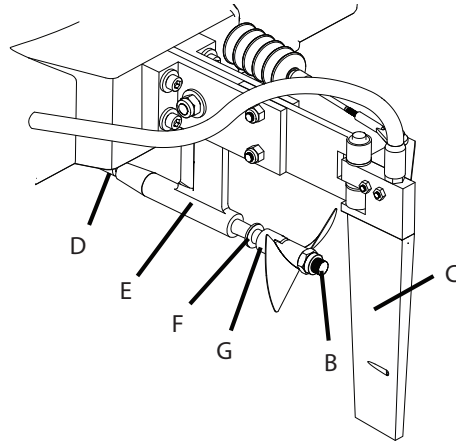

NOTICE : Running the boat in saltwater could cause some parts to corrode. If you run the boat in saltwater, rinse it thoroughly in freshwater after each use and lubricate the drive system.

NOTICE : Because of its corrosive effects, running RC boats in saltwater is at the discretion of the modeler.

Propeller Service

Always replace a damaged propeller.

1. Use a tool to loosen or tighten the prop nut (I) on the prop shaft (F).
2. Align the propeller with the drive dog (J) on the prop shaft and tighten the prop nut.

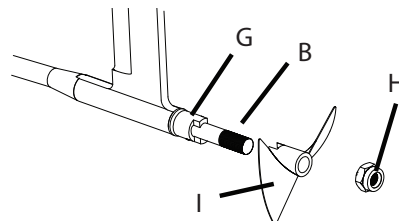

ESC

The included ESC programming card (DYNAM3821) allows you to quickly program your Dynamite® Marine Brushless ESC control settings.

Programmable Settings

Throttle Reverse: ON or OFF

Cutoff Voltage: High Cutoff or Low Cutoff

High Cutoff: The Ni-MH Cutoff voltage is .9 volts per cell and the Li-Po Cutoff is 3.3 volts per cell. High Cutoff allows ample power in reserve after Cutoff for returning the boat to shore.

Low Cutoff: The Ni-MH Cutoff voltage is .7 volts per cell and the Li-Po Cutoff is 3.0 volts per cell. Low Cutoff allows longer run times, but leaves less power in reserve after Cutoff for returning the boat to shore.

Cutoff Type: Idle or Slow Down

Idle: When the Cutoff voltage is reached, the ESC will stop delivering power to the motor.

Slow Down: When the Cutoff voltage is reached, the ESC will drop to 50% power at full throttle.

To reset, return the throttle to neutral.

Brake: ON or OFF

ON: The boat will stop immediately when the throttle is returned to neutral.

OFF: The boat will coast to a stop.

Timing: Low Timing or High Timing

Low Timing: For 2-, 4- or 6-pole inrunner motors. Allows the longest run times.

High Timing: For 6-pole or more inrunner and outrunner motors.

High timing increases both motor RPM and current draw (up to 20% increase compared to low timing) using the same battery pack and prop. Run times will be significantly reduced.

Only use High Timing if the temperatures of the electronic components do not exceed 130°F (54°C) in Low Timing mode.

Throttle Curve: Linear or Logarithm

Linear: The ESC delivers 60% power at half throttle and 100% power at full throttle.

Logarithm: The ESC delivers 45% power at half throttle and 80% power at full throttle (recommended for beginners).

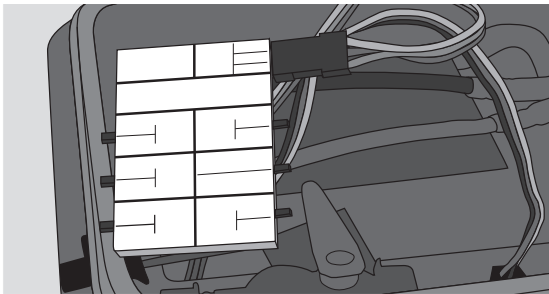

ESC Factory Settings

Reverse	On
Cutoff voltage	High
Cutoff type	Idle
Brake	On
Timing	Low
Throttle Curve	Logarithmic

Using the ESC Programming Card

1. Set all programming card setting switches to the desired positions.
2. Ensure the ESC is powered OFF and disconnected from the batteries.
3. Connect the ESC receiver lead to the ESC port on the programming card, noting proper polarity.
4. Connect a fully charged battery to the ESC or the programming card, then power on the ESC.
5. The ESC will beep, indicating that the new programming has been accepted.
6. After programming is completed, power OFF the ESC, disconnect the ESC receiver lead from the programming card and reconnect it to the throttle port on the receiver, noting proper polarity.
7. To reprogram, power OFF the ESC and disconnect the batteries for 5 seconds, then repeat the steps above.

Checklists

Before Boating

- Install fully charged batteries in your boat and transmitter
- Connect the boat's battery to the ESC
- Make sure the boat is bound to the transmitter (otherwise, bind the boat to the transmitter using the included binding instructions)
- Make sure all linkages move freely on the boat
- Ensure the motor mount is secured to the hull so the motor does not move
- Perform a Control Direction Test with the transmitter
- Adjust the steering rate on your transmitter as desired
- Find a safe and open boating area
- Plan a safe boating route for the water and wind conditions

After Boating

- Always power off the receiver before powering off the transmitter to maintain control of the boat and to retain transmitter binding
- Disconnect the battery from the receiver and remove the batteries from the boat
- Fully dry the inside and outside of the boat, including the water cooling lines and jacket around the motor and ESC. Remove the hatch and radio box cover before storing your boat
- Repair any damage or wear to the boat.
- Lubricate the flex shaft
- Make note of lessons learned from the trimming of your boat, including water and wind conditions

Tip: The hook and loop strips in the boat retain water. To dry them, press on them with a dry cloth.

Troubleshooting Guide

Problem	Possible Cause	Solution
Boat will not respond to throttle but responds to other controls	Throttle servo travel is lower than 100%	Make sure throttle servo travel is 100% or greater
	Throttle channel is reversed	Reverse throttle channel on transmitter
Extra noise or extra vibration	Damaged propeller, shaft or motor	Replace damaged parts
	Propeller is out of balance	Balance or replace propeller
Reduced run time or boat underpowered	Boat battery charge is low	Completely recharge battery
	Boat battery is damaged	Replace boat battery and follow battery instructions
	Blocking or friction on shaft or propeller	Disassemble, lubricate and correctly align parts
	Boat conditions may be too cold	Make sure battery is warm before use
	Battery capacity may be too low for conditions	Replace battery or use a larger capacity battery
	U-joint is too near rudder	Loosen coupling at flex shaft and move flex shaft a small amount
	Too little lubrication on flex shaft	Fully lubricate flex shaft
Boat will not Bind (during binding) to transmitter	Vegetation or other obstacles block the rudder or propeller	Remove boat from the water and obstacles
	Transmitter is too near boat during binding process	Move powered transmitter a few feet from boat, disconnect and reconnect battery to boat
	Boat or transmitter is too close to large metal object, wireless source or another transmitter	Move the boat and transmitter to another location and attempt binding again
	Bind plug is not installed correctly	Install bind plug and bind boat to transmitter
	Boat battery/Transmitter battery charge is too low	Replace/recharge batteries
ESC switch is off	Power on ESC switch	

Troubleshooting Guide

Boat will not connect (after binding) to transmitter	Transmitter is too near boat during connecting process	Move powered transmitter a few feet from boat, disconnect and reconnect battery to boat
	Boat or transmitter is too close to large metal object, wireless source or another transmitter	Move boat or transmitter away from large metal object
	Bind plug is left installed	Rebind transmitter to boat and remove bind plug before cycling power
	Boat battery/transmitter battery charge is too low	Replace/recharge batteries
	ESC switch is off	Power on ESC switch
Boat tends to dive in the water or takes on water	The boat hull is not completely closed	Dry out the boat and ensure the hatch is fully closed on the hull before returning the boat to the water
	Center of gravity is too far forward	Move batteries back in the hull
Boat tends to turn one direction	Rudder or rudder trim is not centered	Repair rudder or adjust rudder and rudder trim for straight running when control is at neutral
Rudder does not move	Rudder, linkage or servo damage	Replace or repair damaged parts and adjust controls
	Wire is damaged or connections are loose	Do a check of wires and connections, connect or replace as needed
	Transmitter is not bound correctly or the incorrect model was selected	Re-bind or select correct model in transmitter
	BEC (Battery Elimination Circuit) of the ESC is damaged	Replace ESC
	ESC switch is off	Power on ESC switch
Controls reversed	Transmitter settings are reversed	Do the Control Direction Test and adjust controls on transmitter appropriately
Motor or ESC overheats	Blocked water cooler tubes	Clean or replace water tubes
Motor power pulses then motor loses power	ESC uses default soft Low Voltage Cut-off (LVC)	Recharge boat battery or replace battery that is no longer performing
	Weather conditions might be too cold	Postpone until weather is warmer
	Battery is old, worn out or damaged	Replace battery

Limited Warranty

What this Warranty Covers

Horizon Hobby, Inc. ("Horizon") warrants to the original purchaser that the product purchased (the "Product") will be free from defects in materials and workmanship at the date of purchase.

What is Not Covered

This warranty is not transferable and does not cover (i) cosmetic damage, (ii) damage due to acts of God, accident, misuse, abuse, negligence, commercial use, or due to improper use, installation, operation or maintenance, (iii) modification of or to any part of the Product, (iv) attempted service by anyone other than a Horizon Hobby authorized service center, (v) Product not purchased from an authorized Horizon dealer, or (vi) Product not compliant with applicable technical regulations.

OTHER THAN THE EXPRESS WARRANTY ABOVE, HORIZON MAKES NO OTHER WARRANTY OR REPRESENTATION, AND HEREBY DISCLAIMS ANY AND ALL IMPLIED WARRANTIES, INCLUDING, WITHOUT LIMITATION, THE IMPLIED WARRANTIES OF NON-INFRINGEMENT, MERCHANTABILITY AND FITNESS FOR A PARTICULAR PURPOSE. THE PURCHASER ACKNOWLEDGES THAT THEY ALONE HAVE DETERMINED THAT THE PRODUCT WILL SUITABLY MEET THE REQUIREMENTS OF THE PURCHASER'S INTENDED USE.

Purchaser's Remedy

Horizon's sole obligation and purchaser's sole and exclusive remedy shall be that Horizon will, at its option, either (i) service, or (ii) replace, any Product determined by Horizon to be defective. Horizon reserves the right to inspect any and all Product(s) involved in a warranty claim. Service or replacement decisions are at the sole discretion of Horizon. Proof of purchase is required for all warranty claims. SERVICE OR REPLACEMENT AS PROVIDED UNDER THIS WARRANTY IS THE PURCHASER'S SOLE AND EXCLUSIVE REMEDY.

Limitation of Liability

HORIZON SHALL NOT BE LIABLE FOR SPECIAL, INDIRECT, INCIDENTAL OR CONSEQUENTIAL DAMAGES, LOSS OF PROFITS OR PRODUCTION OR COMMERCIAL LOSS IN ANY WAY, REGARDLESS OF WHETHER SUCH CLAIM IS BASED IN CONTRACT, WARRANTY, TORT, NEGLIGENCE, STRICT LIABILITY OR ANY OTHER THEORY OF LIABILITY, EVEN IF HORIZON HAS BEEN ADVISED OF THE POSSIBILITY OF SUCH DAMAGES. Further, in no event shall the liability of Horizon exceed the individual price of the Product on which liability is asserted. As Horizon has no control over use, setup, final assembly, modification or misuse, no liability shall be assumed nor accepted for any resulting damage or injury. By the act of use, setup or assembly, the user accepts all resulting liability. If you

as the purchaser or user are not prepared to accept the liability associated with the use of the Product, purchaser is advised to return the Product immediately in new and unused condition to the place of purchase.

Law

These terms are governed by Illinois law (without regard to conflict of law principals). This warranty gives you specific legal rights, and you may also have other rights which vary from state to state. Horizon reserves the right to change or modify this warranty at any time without notice.

WARRANTY SERVICES

Questions, Assistance, and Services

Your local hobby store and/or place of purchase cannot provide warranty support or service. Once assembly, setup or use of the Product has been started, you must contact your local distributor or Horizon directly. This will enable Horizon to better answer your questions and service you in the event that you may need any assistance. For questions or assistance, please visit our website at www.horizonhobby.com, submit a Product Support Inquiry, or call 877.504.0233 toll free to speak to a Product Support representative.

Inspection or Services

If this Product needs to be inspected or serviced and is compliant in the country you live and use the Product in, please use the Horizon Online Service Request submission process found on our website or call Horizon to obtain a Return Merchandise Authorization (RMA) number. Pack the Product securely using a shipping carton. Please note that original boxes may be included, but are not designed to withstand the rigors of shipping without additional protection. Ship via a carrier that provides tracking and insurance for lost or damaged parcels, as Horizon is not responsible for merchandise until it arrives and is accepted at our facility. An Online Service Request is available at http://www.horizonhobby.com/content/_service-center_render-service-center. If you do not have internet access, please contact Horizon Product Support to obtain a RMA number along with instructions for submitting your product for service. When calling Horizon, you will be asked to provide your complete name, street address, email address and phone number where you can be reached during business hours. When sending product into Horizon, please include your RMA number, a list of the included items, and a brief summary of the problem. A copy of your original sales receipt must be included for warranty consideration. Be sure your name, address, and RMA number are clearly written on the outside of the shipping carton.

NOTICE: Do not ship LiPo batteries to Horizon. If you have any issue with a LiPo battery, please contact the appropriate Horizon Product Support office.

Warranty Requirements

For Warranty consideration, you must include your original sales receipt verifying the proof-of-purchase date. Provided warranty conditions have been met, your Product will be serviced or replaced free of charge. Service or replacement decisions are at the sole discretion of Horizon.

Non-Warranty Service

Should your service not be covered by warranty, service will be completed and payment will be required without notification or estimate of the expense unless the expense exceeds 50% of the retail purchase cost. By submitting the item for service you are agreeing to payment of the service without notification. Service estimates are available upon request.

You must include this request with your item submitted for service. Non-warranty service estimates will be billed a minimum of ½ hour of labor. In addition you will be billed for return freight. Horizon accepts money orders and cashier's checks, as well as Visa, MasterCard, American Express, and Discover cards. By submitting any item to Horizon for service, you are agreeing to Horizon's Terms and Conditions found on our website http://www.horizonhobby.com/content/_service-center_render-service-center.

NOTICE: Horizon service is limited to Product compliant in the country of use and ownership. If non-compliant product is received by Horizon for service, it will be returned unserviced at the sole expense of the purchaser.

Parts Contact Information

Country of Purchase	Horizon Hobby	Address	Phone Number/Email Address
United States of America	Sales	4105 Fieldstone Rd Champaign, Illinois 61822 USA	800-338-4539 sales@horizonhobby.com
United Kingdom	Horizon Hobby Limited	Units 1-4 Ployters Rd Staple Tye Harlow, Essex CM18 7NS United Kingdom	+44 (0) 1279 641 097 sales@horizonhobby.co.uk
Germany	Horizon Hobby GmbH	Christian-Junge-Straße 1 25337 Elmshorn, Germany	+49 (0) 4121 2655 100 service@horizonhobby.de
France	Horizon Hobby SAS	14 Rue Gustave Eiffel Zone d'Activité du Réveil Matin 91230 Montgeron	+33 (0) 1 60 47 44 70 infofrance@horizonhobby.com
China	Horizon Hobby China	Room 506, No. 97 Changshou Rd., Shanghai, China 200060	+86 (021) 5180 9868 info@horizonhobby.com.cn

Contact Information

Country of Purchase	Horizon Hobby	Address	Phone Number/Email Address
United States of America	Horizon Service Center (Electronics and engines)	4105 Fieldstone Rd Champaign, Illinois 61822 USA	877-504-0233 Online Repair Request visit: www.horizonhobby.com/service
	Horizon Product Support (All other products)	4105 Fieldstone Rd Champaign, Illinois 61822 USA	877-504-0233 productsupport@horizonhobby.com
United Kingdom	Horizon Hobby Limited	Units 1-4 Ployters Rd Staple Tye Harlow, Essex CM18 7NS United Kingdom	+44 (0) 1279 641 097 sales@horizonhobby.co.uk
Germany	Horizon Technischer Service	Christian-Junge-Straße 1 25337 Elmshorn, Germany	+49 (0) 4121 2655 100 service@horizonhobby.de
France	Horizon Hobby SAS	14 Rue Gustave Eiffel Zone d'Activité du Réveil Matin 91230 Montgeron	+33 (0) 1 60 47 44 70 infofrance@horizonhobby.com
China	Horizon Hobby China	Room 506, No. 97 Changshou Rd., Shanghai, China 200060	+86 (021) 5180 9868 info@horizonhobby.com.cn

FCC Information

This device complies with part 15 of the FCC rules. Operation is subject to the following two conditions:

- (1) This device may not cause harmful interference, and
- (2) This device must accept any interference received, including interference that may cause undesired operation.



CAUTION: Changes or modifications not expressly approved by the party responsible for compliance could void the user's authority to operate the equipment.

This product contains a radio transmitter with wireless technology which has been tested and found to be compliant with the applicable regulations governing a radio transmitter in the 2.400GHz to 2.4835GHz frequency range.

Antenna Separation Distance

When operating your Spektrum transmitter, please be sure to maintain a separation distance of at least 5 cm between your body (excluding fingers, hands, wrists, ankles and feet) and the antenna to meet RF exposure safety requirements as determined by FCC regulations.

The following illustrations show the approximate 5 cm RF exposure area and typical hand placement when operating your Spektrum transmitter.

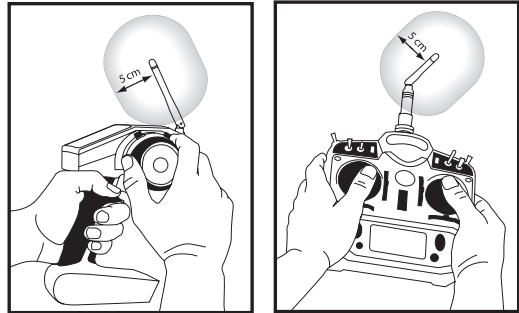

Compliance Information for the European Union

AT	BE	BG	CZ	CY	DE	DK
ES	FI	FR	GR	HU	IE	IT
LT	LU	LV	MT	NL	PL	PT
RO	SE	SI	SK	UK		



Instructions for Disposal of WEEE by Users in the European Union

This product must not be disposed of with other waste. Instead, it is the user's responsibility to dispose of their waste equipment by handing it over to a designated collection point for the recycling of waste electrical and electronic equipment. The separate collection and recycling of your waste equipment at the time of disposal will help to conserve natural resources and ensure that it is recycled in a manner that protects human health and the environment. For more information about where you can drop off your waste equipment for recycling, please contact your local city office, your household waste disposal service or where you purchased the product.



Declaration of Conformity

(in accordance with ISO/IEC 17050-1)

No. HH2012081905

Product(s): PRB Miss Geico 29 BL Catamaran RTR
 Item Number(s): PRB4100B
 Equipment class: 2

The object of declaration described above is in conformity with the requirements of the specifications listed below, following the provisions of the European R&TTE directive 1999/5/EC and EMC Directive 2004/108/EC:

EN 300-328 V1.7.1 : 2006
EN 301 489-1 V1.7.1: 2006
EN 301 489-17 V1.3.2: 2008

EN55022: 2010
EN55024: 2010

Signed for and on behalf of:
 Horizon Hobby, Inc.
 Champaign, IL USA
 Aug 19, 2012

Steven A. Hall
 Executive VP – Chief Operating Officer
 International Operations and Risk Management
 Horizon Hobby, Inc.

Identification of Components / Identifizierung der Komponenten
 Identification des composants / Identificazione dei componenti

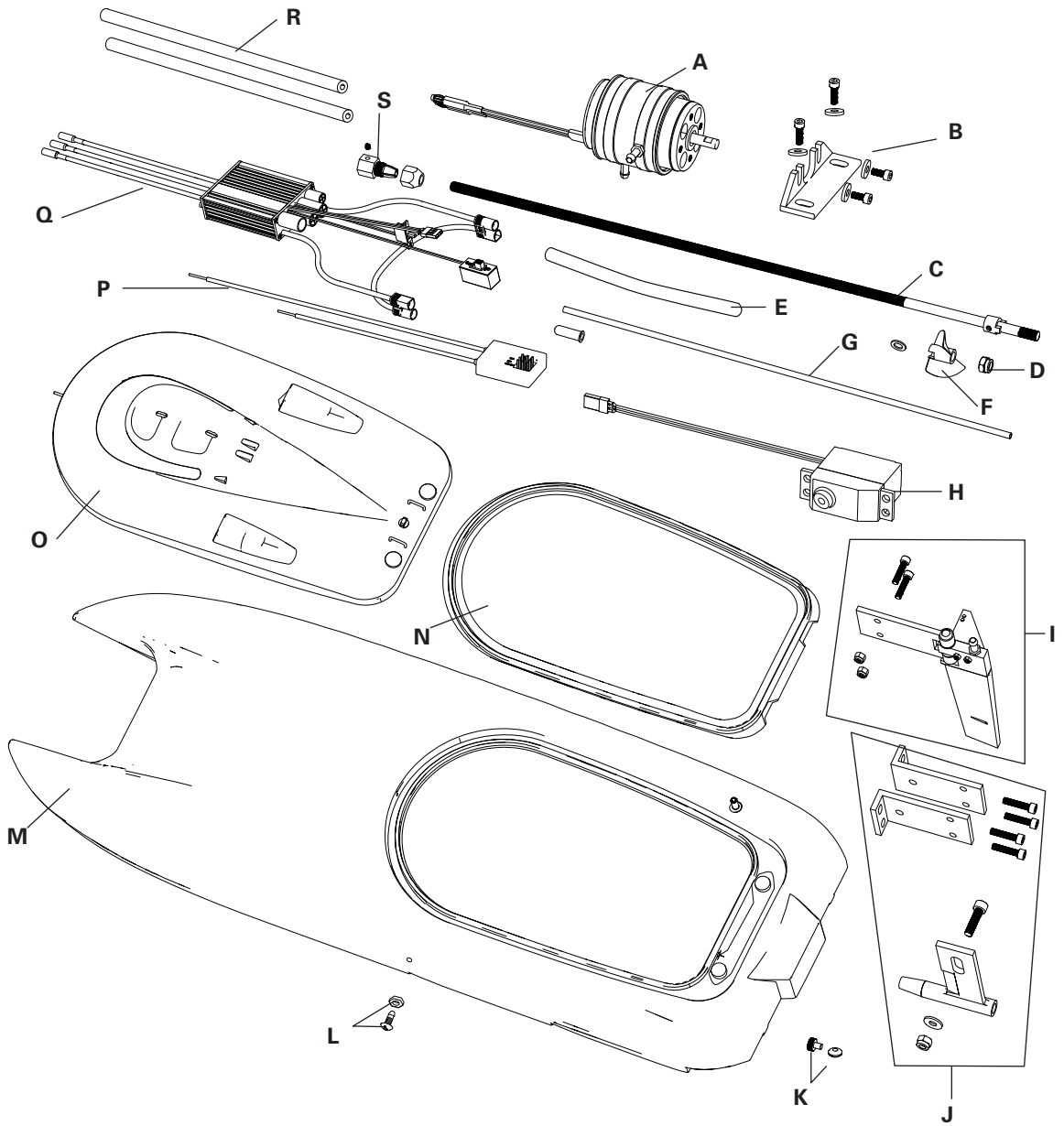

Replacement Parts / Ersatzteile / Pièces de rechange / Pezzi di ricambio

A	PRB3835	1500Kv BL Motor			
B	PRB3307	Motor Mount			
C	PRB4107	Flex shaft			
D	PRB4109	Prop Nut			
E	PRB4113	Flex shaft Liner			
F	PRB0151	Propeller, plastic			
	PRB4111	Rudder Pushrod Set: MG29			
G	PRB4012	Antenna Tube			
H	DYN3900	Digital Servo			
I	PRB4106	Rudder			
J	PRB4105	Strut and Mounts			
K	PRB2239	Drain Plug			
L	PRB2068	Water Outlet and Nut			
M	PRB4101	Hull: MG29			
N	PRB4103	Inner Seal			
O	PRB4102	Canopy: MG29			
P	SPMMR200	Receiver			
Q	DYN3815	60-amp ESC			
R	PRB2224	Silicone Tubing			
S	PRB3308	Collet			
	SPM2300	DX2E Spektrum Transmitter			

Optional Parts / Diverse Teile / Pièces optionnelles / Componenti opzionali

PRB0100	Marine grease	Marinefett	Graisse marine	Grasso marino
PRB0102	Waterproof tape	Clearflex Klebeband	Ruban adhésif imperméable	Nastro impermeabile
PRB4019	Stainless steel prop	Stahlpropeller	Hélice en acier inoxydable	Elica in acciaio inossidabile
DYN4066	Passport™ Sport AC/DC Peak Charger	Passport Sport AC/DC Ladegerät	Chargeur à détection de pics CA/CC Passport	Caricabatterie a rilevamento di picchi CA/CC Passport
DYNP4000EC	Dynamite® Speedpack™ Platinum 7.4V 5200mAh 2S 50C LiPo	Dynamite Speedpack Platinum 5200mAh LiPo 6 Zellen flach	Batterie plate à 6 cellules LiPo 5200 mAh Dynamite Speedpack Platinum	Batteria piatta a 6 celle LiPo 5200 mAh Dynamite Speedpack Platinum

32596 Printed: 7/2012

©2012 Horizon Hobby, Inc.

Pro Boat, DSM, DSM2, Dynamite, Speedpack, Prophet, EC3, the Pro Boat logo and the Horizon Hobby logo are trademarks or registered trademarks of Horizon Hobby, Inc. The Spektrum trademark is used with permission of Bachmann Industries, Inc. All other trademarks, service marks or logos are property of their respective owners.