

RTR
READY-TO-RUN

NIGHT CRAWLER SCALE EDITION SE



Battery and charger sold separately

**INSTRUCTION MANUAL
BEDIENUNGSANLEITUNG
MANUEL D'UTILISATION
MANUALE DI ISTRUZIONI**



Before operating this vehicle, please read all printed materials thoroughly.
Horizon Hobby is not responsible for inadvertent errors in this manual.

NOTICE

All instructions, warranties and other collateral documents are subject to change at the sole discretion of Horizon Hobby, LLC. For up-to-date product literature, visit horizonhobby.com and click on the support tab for this product.

MEANING OF SPECIAL LANGUAGE

The following terms are used throughout the product literature to indicate various levels of potential harm when operating this product:

WARNING: Procedures, which if not properly followed, create the probability of property damage, collateral damage, and serious injury OR create a high probability of superficial injury.

CAUTION: Procedures, which if not properly followed, create the probability of physical property damage AND a possibility of serious injury.

NOTICE: Procedures, which if not properly followed, create a possibility of physical property damage AND a little or no possibility of injury.

WARNING: Read the ENTIRE instruction manual to become familiar with the features of the product before operating. Failure to operate the product correctly can result in damage to the product, personal property and cause serious injury.

This is a sophisticated hobby product. It must be operated with caution and common sense and requires some basic mechanical ability. Failure to operate this Product in a safe and responsible manner could result in injury or damage to the product or other property. This product is not intended for use by children without direct adult supervision. Do not use with incompatible components or alter this product in any way outside of the instructions provided by Horizon Hobby, LLC. This manual contains instructions for safety, operation and maintenance. It is essential to read and follow all the instructions and warnings in the manual, prior to assembly, setup or use, in order to operate correctly and avoid damage or serious injury.

WARNING AGAINST COUNTERFEIT PRODUCTS Always purchase from a Horizon Hobby, LLC authorized dealer to ensure authentic high-quality Spektrum product. Horizon Hobby, LLC disclaims all support and warranty with regards, but not limited to, compatibility and performance of counterfeit products or products claiming compatibility with DSM or Spektrum technology.

Age Recommendation: Not for children under 14 years. This is not a toy.

SAFETY PRECAUTIONS AND WARNINGS

As the user of this product, you are solely responsible for operating in a manner that does not endanger yourself and others or result in damage to the product or property of others.

This model is controlled by a radio signal subject to interference from many sources outside your control. This interference can cause momentary loss of control, so it is advisable to always keep a safe distance in all directions around your model as this margin will help avoid collisions or injury.

- Never operate your model with low transmitter batteries.
- Always operate your model in open spaces away from full-size vehicles, traffic and people.
- Never operate the model in the street or in populated areas for any reason.
- Carefully follow the directions and warnings for this and any optional support equipment (chargers, rechargeable battery packs, etc.) you use.
- Keep all chemicals, small parts and anything electrical out of the reach of children.

- Never lick or place any portion of the model in your mouth as it could cause serious injury or even death.
- Exercise caution when using tools and sharp instruments.
- Take care during maintenance as some parts may have sharp edges.
- Immediately after using your model, do NOT touch equipment such as the motor, electronic speed control and battery, because they generate high temperatures. You may burn yourself seriously touching them.
- Do not put fingers or any objects inside rotating and moving parts, as this may cause damage or serious injury.
- Always turn on your transmitter before you turn on the receiver in the car. Always turn off the receiver before turning your transmitter off.
- Keep the wheels of the model off the ground when checking the operation of the radio equipment.

TABLE OF CONTENTS

BOX CONTENTS	3	ESC CALIBRATION PROCEDURE	6
WATER-RESISTANT VEHICLE WITH WATERPROOF ELECTRONICS	3	CONNECTING THE ESC	6
GENERAL PRECAUTIONS.....	3	PROGRAMMING	6
WET CONDITIONS MAINTENANCE.....	3	DESCRIPTIONS.....	6
QUICK START	3	VEHICLE LEDS	6
CHARGING THE BATTERY	3	DYNAMITE® 540 BRUSHED MOTOR (DYN51216)	7
INSTALLING THE BATTERY	4	PRECAUTIONS	7
TRANSMITTER CONTROLS	4	GEARING	7
INSTALLING THE TRANSMITTER BATTERIES.....	4	CHANGING THE PINION GEAR/GEAR RATIO	7
ESC CALIBRATION	5	SETTING THE GEAR MESH.....	7
BINDING	5	TROUBLESHOOTING GUIDE	7
DRIVING PRECAUTIONS	5	LIMITED WARRANTY	7
POWERING ON THE VEHICLE	5	WARRANTY AND SERVICE CONTACT INFORMATION	8
BEFORE RUNNING YOUR VEHICLE	5	FCC STATEMENT	8
RUN TIME	5	IC INFORMATION	8
TO IMPROVE RUN TIMES.....	5	COMPLIANCE INFORMATION FOR THE EUROPEAN UNION	8
PERFORMING A CONTROL DIRECTION TEST	6	REPLACEMENT PARTS	30–31
DYNAMITE® 60A WATERPROOF FWD/REV BRUSHED ESC (DYN2210)	6	RECOMMENDED PARTS	31
SPECIFICATIONS	6	OPTIONAL PARTS	31
ESC LED STATUS	6	EXPLODED VIEW	32–35
AUDIBLE WARNING TONES	6		

SPECIFICATIONS

Transmitter

Frequency	2.4GHz
Battery	AA x 4

Servo

Power Supply	4.8V~6V
Output Torque	161 oz (4.6 kg-cm)
Operating Speed	0.24sec/60 degrees@6V
Size	40 x 40.5 x 24.5mm

Electronic Speed Control (ESC)

Input Voltage	2–3S LiPo; 5–7 cells NiMH/NiCd
Electric Capacity	60A ESC
BEC Voltage	6V/3A
Size	35.6 x 34 x 18mm
Weight	40 g

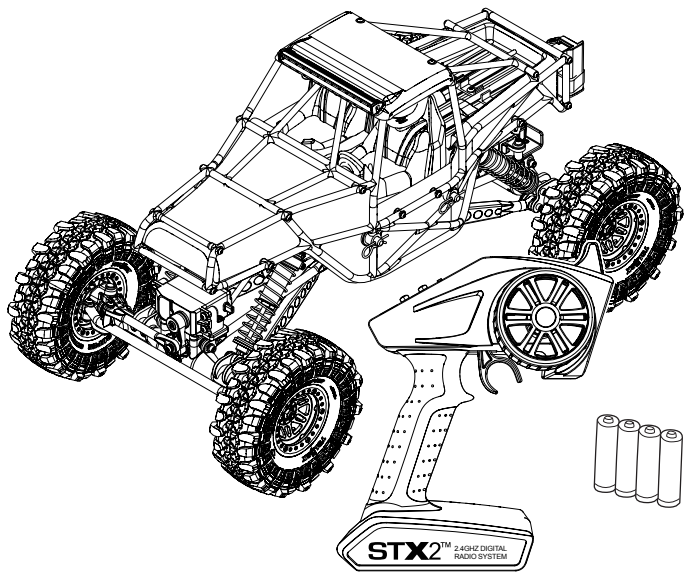

BOX CONTENTS

- Losi® Night Crawler SE RTR: 1/10-Scale 4WD Rock Crawler
- Spektrum™ STX2® 2CH 2.4GHz FHSS Transmitter (SPMSTX200)
- Spektrum™ STX2® 2CH 2.4GHz FHSS Receiver (SPMSRX200)
- Spektrum™ 9KG 23T Waterproof Servo (SPMS605)
- Dynamite® 60A FWD/REV Brushed ESC (DYN52210)
- Dynamite® 35T 540 Brushed Motor (DYN51216)
- 4 AA batteries (for transmitter)

WATER-RESISTANT VEHICLE WITH WATERPROOF ELECTRONICS

Your new Horizon Hobby vehicle has been designed and built with a combination of waterproof and water-resistant components to allow you to operate the product in many “wet conditions,” including puddles, creeks, wet grass, snow and even rain.

While the entire vehicle is highly water-resistant, it is not completely waterproof and your vehicle should NOT be treated like a submarine. The various electronic components used in the vehicle, such as the Electronic Speed Control (ESC), servo(s) and receiver are waterproof, however, most of the mechanical components are water-resistant and should not be submerged.

Metal parts, including the bearings, hinge pins, screws and nuts, as well as the contacts in the electrical cables, will be susceptible to corrosion if additional maintenance is not performed after running in wet conditions. To maximize the long-term performance of your vehicle and to keep the warranty intact, the procedures described in the “Wet Conditions Maintenance” section below must be performed regularly if you choose to run in wet conditions. If you are not willing to perform the additional care and maintenance required, then you should not operate the vehicle in those conditions.

CAUTION: Failure to exercise caution while using this product and complying with the following precautions could result in product malfunction and/or void the warranty.

GENERAL PRECAUTIONS

- Read through the wet conditions maintenance procedures and make sure that you have all the tools you will need to properly maintain your vehicle.
- Not all batteries can be used in wet conditions. Consult the battery manufacturer before use. Caution should be taken when using Li-Po batteries in wet conditions.
- Most transmitters are not water-resistant. Consult your transmitter’s manual or the manufacturer before operation.
- Never operate your transmitter or vehicle where lightning may be present.
- Do not operate your vehicle where it could come in contact with salt water (ocean water or water on salt-covered roads), contaminated or polluted water. Salt water is very conductive and highly corrosive, so use caution.
- Even minimal water contact can reduce the life of your motor if it has not been certified as water-resistant or waterproof. If the motor becomes excessively wet, apply very light throttle until the water is mostly removed from the motor. Running a wet motor at high speeds may rapidly damage the motor.
- Driving in wet conditions can reduce the life of the motor. The additional resistance of operating in water causes excess strain. Alter the gear ratio by using a smaller pinion or larger spur gear. This will increase torque (and motor life) when running in mud, deeper puddles, or any wet conditions that will increase the load on the motor for an extended period of time.

WET CONDITIONS MAINTENANCE

- Drain any water that has collected in the tires by spinning them at high speed. With the body removed, place the vehicle upside down and pull full throttle for a few short bursts until the water has been removed.

CAUTION: Always keep hands, fingers, tools and any loose or hanging objects away from rotating parts when performing the above drying technique.

- Remove the battery pack(s) and dry the contacts. If you have an air compressor or a can of compressed air, blow out any water that may be inside the recessed connector housing.
- Remove the tires/wheels from the vehicle and gently rinse the mud and dirt off with a garden hose. Avoid rinsing the bearings and transmission.

NOTICE: Never use a pressure washer to clean your vehicle.

- Use an air compressor or a can of compressed air to dry the vehicle and help remove any water that may have gotten into small crevices or corners.
- Spray the bearings, drive train, fasteners and other metal parts with a water-displacing light oil. Do not spray the motor.
- Let the vehicle air dry before you store it. Water (and oil) may continue to drip for a few hours.
- Increase the frequency of disassembly, inspection and lubrication of the following:
 - Front and rear axle hub assembly bearings.
 - All transmission cases, gears and differentials.
 - Motor—clean with an aerosol motor cleaner and re-oil the bushings with lightweight motor oil.

QUICK START

Please read the entire manual to gain a full understanding of the vehicle, fine-tuning the setup and performing maintenance.

1. Read the safety precautions found in this manual.
2. Charge a battery for the vehicle. Refer to the included charging warnings and instructions for battery charging information.
3. Install the AA batteries in the transmitter. Only use alkaline or rechargeable batteries.
4. Install the fully charged battery in the vehicle.
5. Power ON the transmitter and then the vehicle. Wait 5 seconds for the ESC to initialize. Always power the transmitter ON before the vehicle and power it OFF after the vehicle has been powered OFF.
6. Check the steering and throttle control directions. Verify that the servos are moving in the correct direction.
7. Drive your vehicle.
8. Perform any necessary maintenance.

CHARGING THE BATTERY

Choose a battery designed to work with the Dynamite® Prophet™ Sport 50W AC/DC Charger (DYN2010CA) or the Dynamite® Prophet™ Sport LiPo 35W AC Charger (DYN20005CA). We recommend the Dynamite® Speedpack® 7.2V 333mAh NiMH 6C Flat with EC3™ connector

(DYN1070EC) or the Dynamite® Reaction® 7.4V 5000mAh2S 20C LiPo hardcase with EC3 connector (DYN9004EC).

INSTALLING THE BATTERY

1. Ensure the ESC is powered OFF.
2. Remove the vehicle body.
3. Connect the battery to the ESC noting the correct polarity.
4. Install the fully charged battery in the vehicle.
5. Secure the battery to the battery tray with hook and loop straps.
6. Power ON the transmitter, then the vehicle.

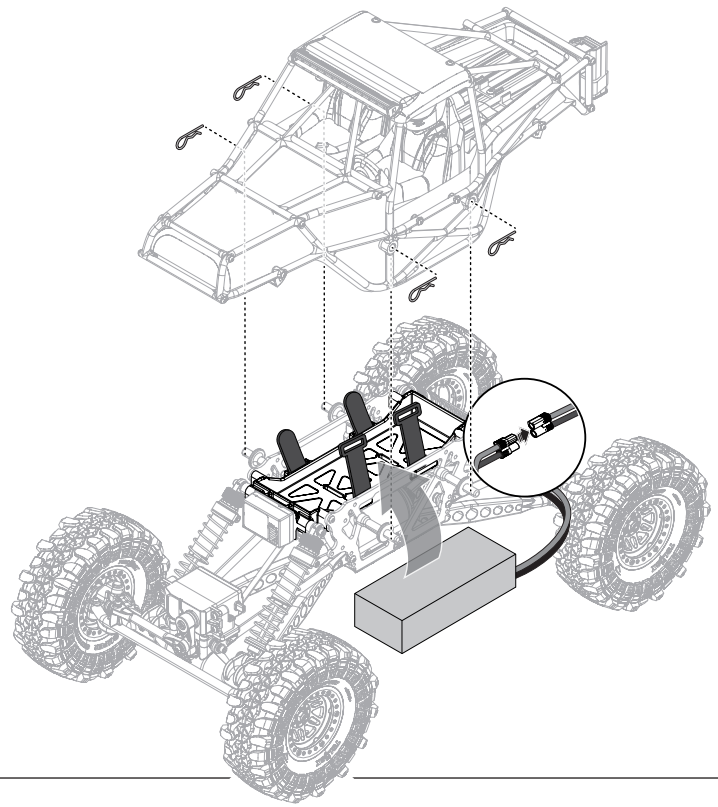

TRANSMITTER CONTROLS

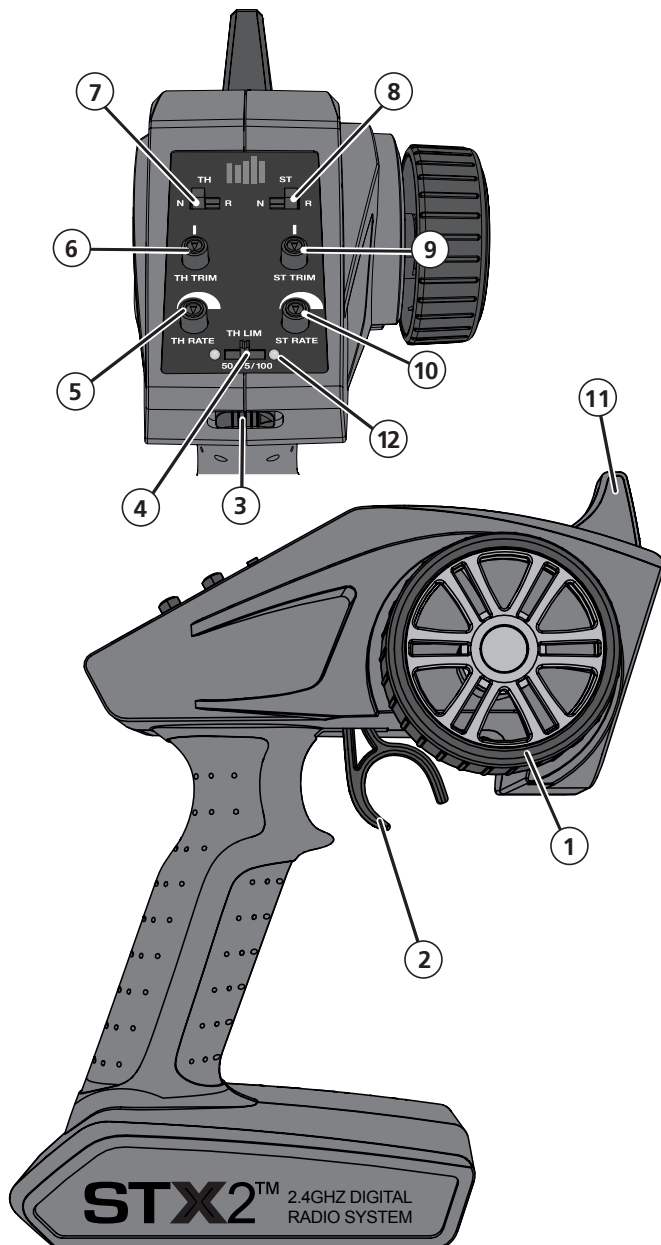

1. **Steering Wheel** Controls direction (left/right) of the model
2. **Throttle Trigger** Controls speed and direction (forward/brake/reverse) of the model
3. **ON/OFF Switch** Turns the power ON/OFF
4. **Throttle Limiting Switch** Adjusts the throttle limit from 50%, 75%, and 100%
5. **TH Rate** Adjusts the end point of the throttle
6. **TH Trim** Adjusts the throttle neutral point
7. **TH REV** Reverses the function of the speed control when pulled back or pushed forward
8. **ST REV** Reverses the function of the steering when the wheel is turned left or right
9. **ST Trim** Adjusts the steering center point
10. **ST Rate** Adjusts the end point of the steering
11. **Antenna** Transmits the signal to the model
12. **Indicator Lights**
 - **Solid red lights**—Indicates radio connectivity and adequate battery power
 - **Flashing red lights**—Indicates the battery voltage is critically low. Replace batteries

INSTALLING THE TRANSMITTER BATTERIES

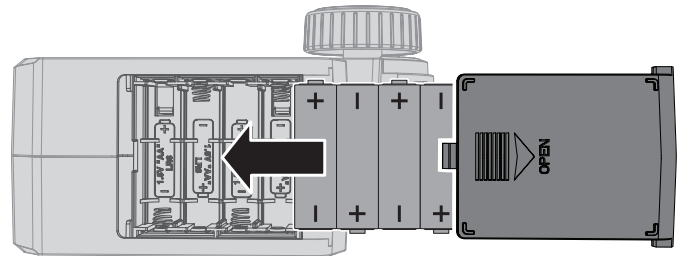

This transmitter requires 4 AA batteries.

1. Remove the battery cover from the transmitter.
2. Install the batteries as shown.
3. Install the battery cover.

CAUTION: If using rechargeable batteries, charge only rechargeable batteries. Charging non-rechargeable batteries may cause the batteries to burst, resulting in injury to persons and/or damage to property.

CAUTION: Risk of explosion if battery is replaced by an incorrect type. Dispose of used batteries according to national regulations.

For more information on the transmitter, go to www.horizonhobby.com and click on the support tab for the Spektrum STX2 to download the instruction manual.

ESC CALIBRATION

Ensure proper ESC function by calibrating the ESC to your transmitter inputs.

1. Power OFF the ESC.
2. Ensure your transmitter is powered ON, the throttle is not reversed, the TR TRIM is neutral and the throttle travel range is at 100%.
Disable any special functions such as ABS, etc.
3. Keep the throttle at neutral and power ON the ESC. The ESC automatically calibrates the throttle range after 3 seconds.
4. One long beep will sound when the ESC is ready to run.

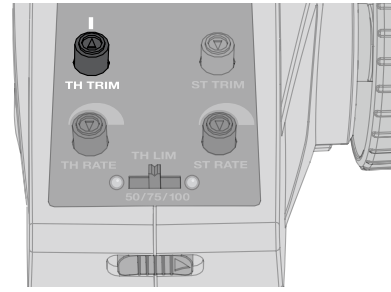

BINDING

Binding is the process of programming the receiver to recognize the GUID (Globally Unique Identifier) code of a single specific transmitter. **The STX2® transmitter and SPMSRX200 receiver are bound at the factory.** If you need to rebind, follow the instructions below:

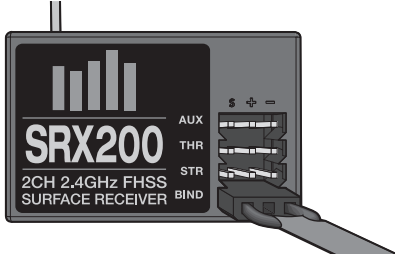

1. Insert the Bind Plug in the BIND port of the ESC.
2. Connect a fully charged battery to the ESC.
3. Power on the ESC. The red receiver LED flashes, indicating the receiver is in bind mode.

4. Center the ST TRIM and TH TRIM dials on the transmitter.
5. Turn the Steering Wheel to Full Right. Power ON the transmitter while holding the Steering Wheel to the Right.
6. Release the Steering Wheel when the receiver LED goes solid.
7. Remove the Bind Plug and store it in a convenient place.
8. Power OFF the ESC to save the settings.
9. Power OFF the transmitter.

You must rebind when:

- When you want different failsafe positions (e.g. when throttle or steering reverse has been changed).
- Binding the receiver to a different transmitter.

NOTICE: Do not attempt to bind the transmitter and receiver if there are other compatible transmitters in bind mode within 400 feet. Doing so may result in unexpected binding.

DRIVING PRECAUTIONS

- Maintain sight of the vehicle at all times.
- Routinely inspect the vehicle for loose wheel hardware.
- Routinely inspect the steering assembly for any loose hardware. Driving the vehicle off-road can cause fasteners to loosen over time.
- Do not drive the vehicle in tall grass. Doing so can damage the vehicle or electronics.
- Stop driving the vehicle when you notice a lack of power. Driving the vehicle when the battery is discharged can cause the receiver to power off. If the receiver loses power, you will lose control of the vehicle. Damage due to an over-discharged Li-Po battery is not covered under warranty.

CAUTION: Do not discharge a Li-Po battery below 3V per cell. Batteries discharged to a voltage lower than the lowest approved voltage may become damaged, resulting in loss of performance and potential fire when batteries are charged.

- Do not apply forward or reverse throttle if the vehicle is stuck. Applying throttle in this instance can damage the motor or ESC.
- After driving the vehicle, allow the electronics to cool before driving the vehicle again.

IMPORTANT: Keep wires away from all moving parts.

POWERING ON THE VEHICLE

1. Center the ST TRIM and TH TRIM dials on the transmitter.
2. Power on the transmitter.
3. Install a fully charged battery pack per the *Installing the Battery* section.
4. Power on the ESC.

IMPORTANT: The vehicle **MUST** remain on a flat, level surface and motionless for at least 5 seconds.

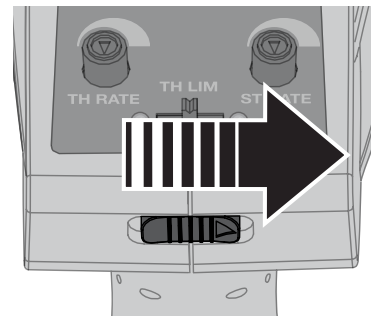

BEFORE RUNNING YOUR VEHICLE

1. Check for free suspension movement. All suspension arms and steering components should move freely. Any binds will cause the vehicle to handle poorly.
Tip: To increase the ride height and ground clearance of your vehicle, install the included shock spacers.
2. Charge a battery pack. Always charge the battery pack as per the battery and/or charger manufacturers' instructions.
3. Set the transmitter steering trim. Follow the instructions to set the steering trim/subtrim so that the vehicle drives straight with no input to the steering.
4. Perform a Control Direction Test.

RUN TIME

The largest factor in run time is the capacity of the battery pack. A larger mAh rating increases the amount of run time experienced.

The condition of a battery pack is also an important factor in both run time and speed. The battery connectors may become hot during driving. Batteries will lose performance and capacity over time.

Driving the vehicle from a stop to full speed repeatedly will damage the batteries and electronics over time. Sudden acceleration will also lead to shorter run times.

TO IMPROVE RUN TIMES

- Keep your vehicle clean and well maintained.
- Allow more airflow to the ESC and motor.
- Change the gearing to a lower ratio. A lower ratio decreases the operating temperature of the electronics. Use a smaller pinion gear or larger spur gear to lower the gear ratio.
- Use a battery pack with a higher mAh rating.
- Use the optimum charger to charge battery packs (Visit your local hobby dealer for more information).

PERFORMING A CONTROL DIRECTION TEST

Perform a control test with the vehicle wheels off the ground. If the wheels rotate after the vehicle is powered ON, adjust the TH Trim knob until they stop. To make the wheels move forward, pull the trigger. To reverse them, wait for the wheels to stop, then push the trigger. When moving forward, the wheels should maintain a straight line without any steering wheel input. If not, adjust the ST Trim knob, so the wheels maintain a straight line without having to turn the steering wheel.

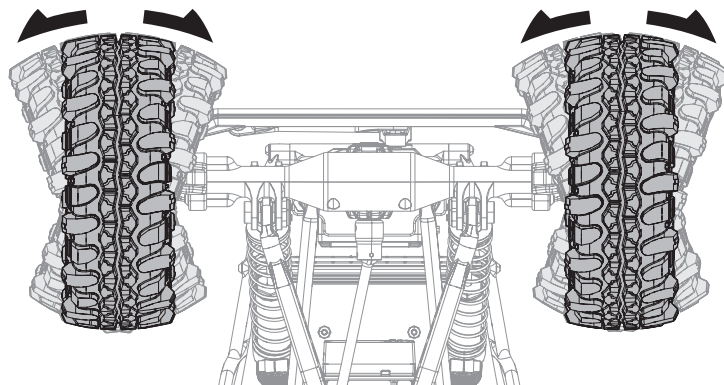

DYNAMITE® 60A WATERPROOF FWD/REV BRUSHED ESC (DYN2210)

SPECIFICATIONS

Type	Brushed
Constant/Peak	60A/360A
Resistance	0.0008 Ohms
Function	Forward/Brake/Reverse, Forward/Brake, Forward/Reverse (Crawler Mode)
Vehicle Type	1/10 on-road and off-road; 1/10 rock crawler
Operation	Proportional forward, proportional reverse with braking delay, Crawler Mode
Battery Type/Input Voltage	2-3 cell Li-Po/Li-Fe; 5-7 cell Ni-MH/Ni-Cd
Motor Type	540-/550-size closed endbell motors: 2S Li-Po down to 12T; 3S Li-Po down to 35T
BEC Output	6V/3A
Overload Protection	Thermal
Dimensions	35.6mm x 34mm x 18mm (1.40 in x 1.34 in x 0.71 in)
Weight	40 g (1.41 oz) with wires
Battery Connector	EC3™ connector
Motor Connector	3.5mm Tamiya-style bullet

ESC LED STATUS

- No ESC LEDs will glow when there is no throttle input from the transmitter.
- The red ESC LED glows when there is any throttle input from the transmitter.

AUDIBLE WARNING TONES

- Input Voltage:** The ESC checks the input voltage when it is powered ON. If a voltage problem is detected, the ESC continuously sounds 2 beeps with a 1 second pause (xx-xx-xx). Power OFF the ESC and ensure the connections are secure and that the battery power is not too low for safe operation.
- Radio Connection:** The ESC checks radio signal input when it is powered ON. If a problem is detected, the ESC continuously sounds 1 beep with a 2 second pause (x--x--x). Power OFF the ESC and ensure the radio system is operating correctly.

ESC CALIBRATION PROCEDURE

Ensure proper ESC function by calibrating the ESC to your transmitter inputs.

1. Power OFF the ESC.
2. Ensure your transmitter is powered ON, the throttle is not reversed, the throttle trim is neutral and the throttle travel range is at 100%. Disable any special functions such as ABS, etc.
3. Keep the throttle at neutral and power ON the ESC.
4. The ESC automatically calibrates the throttle range after 3 seconds. One long beep will sound when the ESC is ready to run.

VEHICLE LEDs

Plug the Rock Lights on the vehicle into the AUX CH on the receiver.
Plug the Cage LEDs into the BIND port on the receiver.

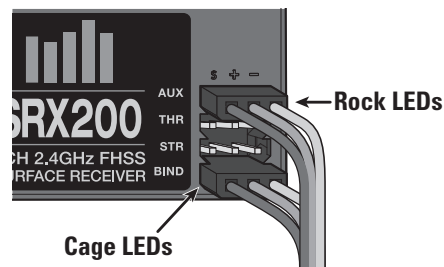

CONNECTING THE ESC

1. Connect the RED (+) ESC wire to the RED (+) motor wire.
2. Connect the BLACK (-) ESC wire to the BLACK (-) motor wire.

NOTICE: Always disconnect the battery from the ESC when you have finished operating your vehicle. The ESC's switch only controls power to the receiver and servos. The ESC will continue to draw current when connected to the battery, resulting in possible damage to the battery through over discharge.

PROGRAMMING

The ESC comes with two jumpers pre-installed in the MODE: F/B (forward/brake) and BATT: Li-Po configurations.

To change the mode to F/B/R (forward/brake/reverse) or F/R (forward/reverse) or change the battery type to Ni-MH.

1. Power OFF the ESC.
2. Disconnect the jumper from the default port and connect it to the desired port.
3. Power ON the ESC.

If the jumpers are lost or not installed, the ESC will default to MODE: F/B/R and BATT: Li-Po.

WARNING: Do not connect bind plugs or receiver servo leads into the ESC programming port. Doing so may damage the ESC and/or components.

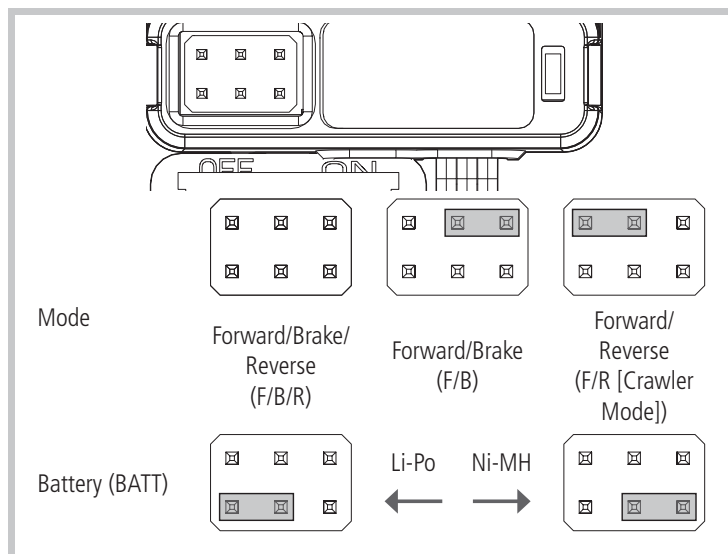

DYNAMITE® 540 BRUSHED MOTOR 35T (DYS1216)

PRECAUTIONS

- Never touch moving parts.
- Never disassemble while the batteries are installed.
- Always let parts cool before touching.

GEARING

Your vehicle has been equipped with the optimal gearing for the stock platform. It offers an ideal balance between speed, power and efficiency. Should you decide to customize your vehicle with optional batteries or motors, it may be necessary for you to change the pinion or spur gear.

Installing a pinion gear with fewer teeth or a spur gear with more teeth will provide greater torque but will reduce top speed. Likewise, a pinion gear with more teeth or a spur gear with fewer teeth will reduce torque and increase top speed. Care should be taken when installing larger pinion gears as this can “overgear” the vehicle, resulting in overheating of the motor and ESC. When testing different gearing options, pay close attention to the temperature of the motor and speed control to ensure you are operating within the temperature range of the components. The motor or ESC should never be so hot that it cannot be touched. If temperatures are too hot, a different gearing combination with a lower pinion gear and/or higher spur gear is suggested.

CHANGING THE PINION GEAR/GEAR RATIO

The following instructions are for replacing a worn pinion gear. If you are changing the pinion gear size please refer to “Setting the Gear Mesh.”

1. Loosen the pinion gear set screw to remove the installed pinion gear.
2. Loosen the motor screws and slide the motor back.
3. Place the new pinion on the end of the motor shaft so the set screw is located over the flat area on the shaft.
4. Position the teeth on the pinion gear so they line up with the spur gear and secure the pinion gear onto the motor shaft by tightening the set screw.

SETTING THE GEAR MESH

The gear mesh has already been set at the factory. Setting it is only necessary when changing motors or gears.

Proper gear mesh (how gear teeth meet) is important to the performance of the vehicle. When the gear mesh is too loose, the spur gear could be damaged by the pinion gear on the motor. If the mesh is too tight, speed could be limited and the motor and ESC will overheat.

1. Loosen the motor screws and slide the motor back.
2. Put a small piece of paper between the pinion and spur gears.
3. Push the gears together with moderate pressure and hold in place while tightening the motor screws.
4. Remove the paper. Check the mesh at 3–5 different locations around the spur gear for minimal movement.

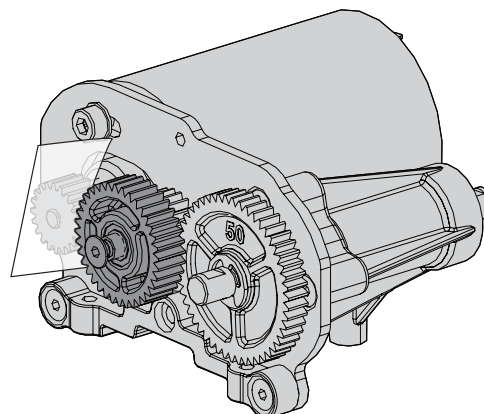

TROUBLESHOOTING GUIDE

PROBLEM	POSSIBLE CAUSE	SOLUTION
Vehicle does not operate	Battery not charged or plugged in	Charge battery/plug in
	ESC switch not “On”	Turn on ESC switch
	Transmitter not “On” or low battery	Turn on/replace batteries
Motor runs but wheels do not rotate	Pinion not meshing with spur gear	Adjust pinion/spur mesh
	Pinion spinning on motor shaft	Tighten pinion gear setscrew on motor shaft flat spot
	Transmission gears stripped	Replace transmission gears
	Drive pin broken	Check and replace drive pin
Steering does not work	Servo plug not in receiver properly	Make sure the steering servo plug is connected to the receiver steering channel, noting proper polarity
	Servo gears or motor damaged	Replace or repair servo
Will not turn one direction	Servo gears damaged	Replace or repair servo
	Motor wire solder joint is damaged	Resolder the motor wire with the proper equipment
Motor does not run	Motor wire broken	Repair or replace as needed
	ESC damaged	Contact Horizon Hobby Product Support
	Motor over-gear	Use smaller pinion or larger spur gear
ESC gets hot	Driveline bound up	Check wheels and transmission for binding
	Battery pack not fully charged	Recharge battery
	Charger not allowing full charge	Try another charger
Poor run time and/or sluggish acceleration	Driveline bound up	Check wheels, transmission for binding
	Transmitter batteries low	Check and replace
	Vehicle battery low	Recharge battery
Poor range and/or glitching	Loose plugs or wires	Check all wire connections and plugs

LIMITED WARRANTY

What this Warranty Covers

Horizon Hobby, LLC, (Horizon) warrants to the original purchaser that the product purchased (the “Product”) will be free from defects in materials and workmanship at the date of purchase.

What is Not Covered

This warranty is not transferable and does not cover (i) cosmetic damage, (ii) damage due to acts of God, accident, misuse, abuse, negligence, commercial use, or due to improper use, installation, operation or maintenance, (iii) modification of or to any part of the Product, (iv) attempted service by anyone other than a Horizon Hobby authorized service center, (v) Product not purchased from an authorized Horizon dealer, or (vi) Product not compliant with applicable technical regulations or (vii) use that violates any applicable laws, rules, or regulations. OTHER THAN THE EXPRESS WARRANTY ABOVE, HORIZON MAKES NO OTHER WARRANTY OR REPRESENTATION, AND HEREBY DISCLAIMS ANY AND ALL IMPLIED WARRANTIES,

INCLUDING, WITHOUT LIMITATION, THE IMPLIED WARRANTIES OF NON-INFRINGEMENT, MERCHANTABILITY AND FITNESS FOR A PARTICULAR PURPOSE. THE PURCHASER ACKNOWLEDGES THAT THEY ALONE HAVE DETERMINED THAT THE PRODUCT WILL SUITABLY MEET THE REQUIREMENTS OF THE PURCHASER’S INTENDED USE.

Purchaser’s Remedy

Horizon’s sole obligation and purchaser’s sole and exclusive remedy shall be that Horizon will, at its option, either (i) service, or (ii) replace, any Product determined by Horizon to be defective. Horizon reserves the right to inspect any and all Product(s) involved in a warranty claim. Service or replacement decisions are at the sole discretion of Horizon. Proof of purchase is required for all warranty claims. SERVICE OR REPLACEMENT AS PROVIDED UNDER THIS WARRANTY IS THE PURCHASER’S SOLE AND EXCLUSIVE REMEDY.

Limitation of Liability

HORIZON SHALL NOT BE LIABLE FOR SPECIAL, INDIRECT, INCIDENTAL OR CONSEQUENTIAL DAMAGES, LOSS OF PROFITS OR PRODUCTION OR COMMERCIAL LOSS IN ANY WAY, REGARDLESS OF WHETHER SUCH CLAIM IS BASED IN CONTRACT, WARRANTY, TORT, NEGLIGENCE, STRICT LIABILITY OR ANY OTHER THEORY OF LIABILITY, EVEN IF HORIZON HAS BEEN ADVISED OF THE POSSIBILITY OF SUCH DAMAGES. Further, in no event shall the liability of Horizon exceed the individual price of the Product on which liability is asserted. As Horizon has no control over use, setup, final assembly, modification or misuse, no liability shall be assumed nor accepted for any resulting damage or injury. By the act of use, setup or assembly, the user accepts all resulting liability. If you as the purchaser or user are not prepared to accept the liability associated with the use of the Product, purchaser is advised to return the Product immediately in new and unused condition to the place of purchase.

Law

These terms are governed by Illinois law (without regard to conflict of law principals). This warranty gives you specific legal rights, and you may also have other rights which vary from state to state. Horizon reserves the right to change or modify this warranty at any time without notice.

WARRANTY SERVICES

Questions, Assistance, and Services

Your local hobby store and/or place of purchase cannot provide warranty support or service. Once assembly, setup or use of the Product has been started, you must contact your local distributor or Horizon directly. This will enable Horizon to better answer your questions and service you in the event that you may need any assistance. For questions or assistance, please visit our website at www.horizonhobby.com, submit a Product Support Inquiry, or call the toll free telephone number referenced in the Warranty and Service Contact Information section to speak with a Product Support representative.

Inspection or Services

If this Product needs to be inspected or serviced and is compliant in the country you live and use the Product in, please use the Horizon Online Service Request submission process found on our website or call Horizon to obtain a Return Merchandise Authorization (RMA) number. Pack the Product securely using a shipping carton. Please note that original boxes may be included, but are not designed to withstand the rigors of shipping without additional protection. Ship via a carrier that provides tracking and insurance for lost or damaged parcels, as Horizon is not responsible for merchandise until it arrives and is accepted at our facility. An Online Service Request is available at [http://www.horizonhobby.com/content/service-](http://www.horizonhobby.com/content/service-center_render-service-center)

[center_render-service-center](http://www.horizonhobby.com/content/service-center_render-service-center). If you do not have internet access, please contact Horizon Product Support to obtain a RMA number along with instructions for submitting your product for service. When calling Horizon, you will be asked to provide your complete name, street address, email address and phone number where you can be reached during business hours. When sending product into Horizon, please include your RMA number, a list of the included items, and a brief summary of the problem. A copy of your original sales receipt must be included for warranty consideration. Be sure your name, address, and RMA number are clearly written on the outside of the shipping carton.

NOTICE: Do not ship Li-Po batteries to Horizon. If you have any issue with a Li-Po battery, please contact the appropriate Horizon Product Support office.

Warranty Requirements

For Warranty consideration, you must include your original sales receipt verifying the proof-of-purchase date. Provided warranty conditions have been met, your Product will be serviced or replaced free of charge. Service or replacement decisions are at the sole discretion of Horizon.

Non-Warranty Service

Should your service not be covered by warranty, service will be completed and payment will be required without notification or estimate of the expense unless the expense exceeds 50% of the retail purchase cost. By submitting the item for service you are agreeing to payment of the service without notification. Service estimates are available upon request. You must include this request with your item submitted for service. Non-warranty service estimates will be billed a minimum of ½ hour of labor. In addition you will be billed for return freight. Horizon accepts money orders and cashier's checks, as well as Visa, MasterCard, American Express, and Discover cards. By submitting any item to Horizon for service, you are agreeing to Horizon's Terms and Conditions found on our website http://www.horizonhobby.com/content/service-center_render-service-center.

ATTENTION: Horizon service is limited to Product compliant in the country of use and ownership. If received, a non-compliant Product will not be serviced. Further, the sender will be responsible for arranging return shipment of the un-serviced Product, through a carrier of the sender's choice and at the sender's expense. Horizon will hold non-compliant Product for a period of 60 days from notification, after which it will be discarded.

10/15

WARRANTY AND SERVICE CONTACT INFORMATION

Country of Purchase	Horizon Hobby	Contact Information	Address
United States of America	Horizon Service Center (Repairs and Repair Requests)	servicecenter.horizonhobby.com/RequestForm/	4105 Fieldstone Rd. Champaign, Illinois 61822 USA
	Horizon Product Support (Product Technical Assistance)	productsupport@horizonhobby.com 877-504-0233	
	Sales	websales@horizonhobby.com 800-338-4639	
European Union	Horizon Technischer Service	service@horizonhobby.eu +49 (0) 4121 2655 100	Hanskampring 9 D 22885 Barsbüttel, Germany
	Sales: Horizon Hobby GmbH		

FCC STATEMENT

FCC ID: 2AI3D-SS0001

This equipment has been tested and found to comply with the limits for Part 15 of the FCC rules. These limits are designed to provide reasonable protection against harmful interference in a residential installation. This equipment generates uses and can radiate radio frequency energy and, if not installed and used in accordance with the instructions, may cause harmful interference to radio communications.

However, there is no guarantee that interference will not occur in a particular installation. If this equipment does cause harmful interference to radio or television reception, which can be determined by turning the equipment off and on, the user is encouraged to try to correct the interference by one or more of the following measures:

- Reorient or relocate the receiving antenna.
- Increase the separation between the equipment and receiver.
- Connect the equipment to an outlet on a circuit different from that to which the receiver is connected.

This device complies with part 15 of the FCC rules. Operation is subject to the following two conditions: (1) This device may not cause harmful interference, and (2) this device must accept any interference received, including interference that may cause undesired operation.

NOTICE: Modifications to this product will void the user's authority to operate this equipment.

RF Radiation Exposure Statement

1. This Transmitter must not be co-located or operating in conjunction with any other antenna or transmitter.
2. This equipment complies with FCC RF radiation exposure limits set forth for an uncontrolled environment. This equipment should be installed and operated with a minimum distance of 20 centimeters between the radiator and your body.

Antenna Separation Distance

When operating your Spektrum transmitter, please be sure to maintain a separation distance of at least 20 cm between your body (excluding fingers, hands, wrists, ankles and feet) and the antenna to meet RF exposure safety requirements as determined by FCC regulations.

The illustration shows the approximate 20 cm RF exposure area and typical hand placement when operating your Spektrum transmitter.

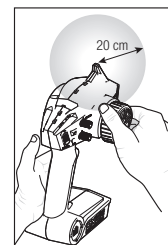

IC INFORMATION

IC: 21682-SSTC9202

This device complies with Industry Canada licence-exempt RSS standard(s). Operation is subject to the following two conditions: (1) this device may not cause interference, and (2) this device must accept any interference, including interference that may cause undesired operation of the device.

COMPLIANCE INFORMATION FOR THE EUROPEAN UNION



EU Compliance Statement: Horizon Hobby, LLC hereby declares that this product is in compliance with the essential requirements and other relevant provisions of the RED and EMC Directive.

A copy of the EU Declaration of Conformity is available online at: <http://www.horizonhobby.com/content/support-render-compliance>.



Instructions for disposal of WEEE by users in the European Union

This product must not be disposed of with other waste. Instead, it is the user's responsibility to dispose of their waste equipment by handing it over to a designated collections point for the recycling of waste electrical and electronic equipment. The separate collection and recycling of your waste equipment at the time of disposal will help to conserve natural resources and ensure that it is recycled in a manner that protects human health and the environment. For more information about where you can drop off your waste equipment for recycling, please contact your local city office, your household waste disposal service or where you purchased the product.

REPLACEMENT PARTS // TEILELISTE // LISTE DES PIÈCES DE RECHANGE // ELENCO DEI RICAMBI

Part #	English	Deutsch	Français	Italiano
DYN3205	4 x 8 Unflanged Ball Bearing	4 x 8 flanschloses Kugellager	Roulement à billes sans collet 4 x 8	4 x 8 cuscinetti a sfera senza flangia
DYNS1216	Dynamite 35T 540 Brushed Motor	Dynamite 35T 540 Bürstenmotor	Moteur à balais Dynamite 35T 540	Motore a spazzole Dynamite 35T 540
DYNS2210	WP 60A FWD/REV Brushed ESC	WP 60A FWD/REV Bürstengeschwindigkeitsregler	Variateur ESC à balais AV/AR WP 60A	WP 60A FWD/REV Brushed ESC
LOS230005	LED Light Board & Housing	LED-Leuchtplatine & Gehäuse	Panneau et boîtier à DEL	Scheda luci LED e alloggiamento
LOS230047	Roll Cage Set	Überrollkäfig-Set	Ensemble de cage de retournement	Set scocca di sicurezza
LOS230048	Accessory Pack	Zubehörpaket	Pack d'accessoires	Pacchetto accessori
LOS230049	3-Way Splitter	3fach-Splitter	Diviseur à trois voies	Splitter a 3 vie
LOS230050	Body Set w/Drivers, Clear	Karoseriesatz mit Fahrern, farblos	Ensemble carrosserie avec outils d'assemblage, transparent	Set carrozzeria con piloti, trasparente
LOS231004	Side Plate Set, Chassis, Black	Seitenplattensatz, Karosserie, Schwarz	Ensemble de plaques latérales, châssis, noir	Set lamiera laterale, telaio, nero
LOS233000	2.5" Spring 3.4 Rate, Black (4)	2,5" Feder 3,4 Federrate, Schwarz (4)	Ressort de 2,5 po, raideur 3,4, noir (4)	Molla 2,5", grado 3,4, nero (4)
LOS234001	1.2" Shock Body, Silver (4)	1,2" Dämpfer, Silber (4)	Corps d'amortisseur de 1,2 po, argent (4)	Corpo ammortizzatore 1,2", argento (4)
LOS235003	M3 x 6mm Cap Head Screws (10)	M3 x 6mm Inbusschraube (10)	Vis d'assemblage creuses M3 x 6 mm (10)	Viti a testa tonda M3 x 6 (10)
LOSA4120	48 Pitch Pinion Gear, 20T	48 Pitchzahnradgetriebe, 20T	Engrenage à pignons pas 48, 20T	Pignone 20T, pitch 48
LOSA1030	Spindle & Carrier Set	Spindel- & Trägersatz	Ensemble axe et support	Set fuselli e portafuselli
LOSA1033	Upper Suspension Link Mount	Obere Aufhängungsarm der Halterung	Support pour bras de suspension supérieur	Supporto braccetto sospensione superiore
LOSA1034	Lower Suspension Link, Mounts & Pin	Obere Unterfederungsarm, Halterung & Stift	Bras de suspension inférieur, supports et broche	Supporti braccetto sospensione inferiori e perno
LOSA1517	Steering King Pins & Hardware	Steuerung Königszapfen & Hardware	Pivots de fusée et matériel	King pin sterzo e bulloneria
LOSA2030	Rear Outer Hub, Cap & Hardware	Heckaußennabe, Kappe & Hardware	Moyeu extérieur arrière, cache et matériel	Mozzo esterno posteriore, coperchio e bulloneria
LOSA3184	Rear Axle	Hinterachse	Essieu arrière	Assale posteriore
LOSA3185	Rear Axle Spacer Set, Aluminium	Hinterachse Distanzstücksatz, Aluminium	Ensemble d'entretoises pour essieu arrière, alum.	Set distanziale assale posteriore, alluminio
LOSA3187	HD Worm Gear Set, 21T (2)	HD Schneckengetriebesatz, 21T (2)	Engrenage à vis sans fin, ultra-résistant, 21T (2)	Set vite senza fine HD, 21T (2)
LOSA3194	Front & Center CV Rebuild Kit	Front & Mitte-CV Umbau Kit	Kit de réparation homocinétique avant et centre	Kit ricostruzione CV anteriore e posteriore
LOSA3196	Front CV Drive Shaft Set, HD	Front CV Antriebswelle Satz, HD	Jeu d'arbres de transmission avant homocinétiques, ultra-résistant	Set albero di trasmissione CV anteriore, HD
LOSA3197	Front CV Axle HD	Front CV Achse HD	Essieu avant homocinétique, ultra-résistant	Assale CV anteriore, HD
LOSA3198	Front CV Drive Shaft HD	Front CV Antriebswelle, HD	Arbre de transmission homocinétique avant, ultra-résistant	Albero di trasmissione CV anteriore, HD
LOSA3199	CV Pin Retainer Clip 11mm Pins	CV Befestigungsklemme 11mm Pins	Bague de retenue avec axes homocinétiques, axes de 11 mm	Morsetto di fermo perno CV, perni 11 mm
LOSA4009	Battery Straps, Hook/Loop (2)	Akkuklemmen, Haken/Schlaufen (2)	Sangles de batterie, velcro (2)	Fascette a strappo batteria (2)
LOSA4012	Front/Rear Axle Case Set	Front/Hinterachse-Gehäusesatz	Jeu de carters d'essieu avant/arrière	Set scatola assale anteriore/posteriore
LOSA4036	ESC Platform	Geschwindigkeitsregler-Plattform	Plateforme ESC	Piattaforma ESC
LOSA4037	Servo Mnts, Plate & Hardware	Servo-Halterung, Platte & Hardware	Supports, plaque et matériel pour servo	Supporti servo, piastra e bulloneria
LOSA4039	Transmission Skid Plate: CCR	Getriebe Gleitbrett: CCR	Plaque de protection pour transmission : CCR	Piastra proteggi trasmissione: CCR
LOSA5012	Upper Shock Bushings and Lower Shock Pivot Ball (4)	Obere Dämpferlager und untere Dämpferschwenkkugel (4)	Bagues supérieures d'amortisseur et Rotule inférieure d'amortisseur (4)	Boccole ammortizzatore superiori e articolazione a rotula ammortizzatore inferiore (4)
LOSA5015	Double O-Ring Shock Cartridge	Doppel-O-Ring Stoßdämpfer	Cartouche d'amortisseur à double joint torique	Doppio O-Ring cartucce ammortizzatore
LOSA5023	Shock Spring Clamps & Cups	Stoßdämpfer-Federspanner & Federteller	Brides et coupelles de ressort d'amortisseur	Morsetti e coppe molle ammortizzatori
LOSA5062	Shock Shaft, 1.2" Ti-Nitride	Kolbenstange, 1.2" Ti-Nitrid	Arbre d'amortisseur, 1,2 po, nitrure de titane	Stelo ammortizzatore, 1.2" Ti-Nitride
LOSA5079	Shock Ends & Cups (4)	Stoßdämpferenden und Teller (4)	Embouts et coupelles d'amortisseur (4)	Terminali e coppe ammortizzatori (4)
LOSA6045	HD Steering Link Set	HD Lenkgliedset	Timonerie de direction, ultra-résistante	Set braccetti sterzo HD
LOSA6100	1/8" E-Clips	1/8" E-Klemmen	Clips en e, 3 mm (1/8 po)	E-Clip, 1/8"
LOSA6109	E-Clips, 5mm (12)	E-Klemmen, 5mm (12)	Clips en e, 5 mm (12)	E-Clip, 5 mm (12)
LOSA6201	3mm x 6mm Socket Head Screw	3mm x 6mm Innensechskantschraube	Vis à pans creux 3 mm x 6 mm	Vite a brugola 3 x 6 mm
LOSA6206	4-40 x 3/8" Socket Head Screws (10)	4-40 x 3/8 Innensechskantschrauben (10)	Vis à 6 pans creux 4-40 x 3/8 po (10)	Viti a brugola 4-40 x 3/8" (10)
LOSA6210	4-40 x 3/8" Flat Head Socket	4-40 x 3/8 Flachkopfbuchse	Vis à tête fraisée à 6 pans creux 4-40 x 3/8 po	Vite a testa piatta 4-40 x 3/8"
LOSA6213	4-40 x 1/4" Flat Socket Screw (6)	4-40 x 1/4 Flachkopf-Zylinderschraube (6)	Vis à tête fraisée à 6 pans creux 4-40 x 1/4 po (6)	Viti a testa piatta 4-40 x 1/4" (6)
LOSA6221	4-40 x 5/8" Cap Screws (6)	4-40 x 5/8 Kopfschrauben (6)	Vis d'assemblage 4-40 x 5/8 po (6)	Viti a brugola 4-40 x 5/8" (6)
LOSA6228	5-40 x 1/8" Hardened Setscrews (10)	5-40 x 1/8 Gehärtete Feststellschrauben (10)	Vis de fixation en acier trempé 5-40 x 1/8 po (10)	Viti di arresto indurite 5-40 x 1/8" (10)
LOSA6229	4-40 x 3/8" Button Head Screws	4-40 x 3/8 Rundkopfschrauben	Vis à tête bombée 4-40 x 3/8 po	Viti a testa tonda 4-40 x 3/8"
LOSA6245	4-40 x 5/16" Button Head Screws (10)	4-40 x 5/16 Rundkopfschrauben (10)	Vis à tête bombée 4-40 x 5/16 po (10)	Viti a testa tonda 4-40 x 5/16" (10)
LOSA6248	4-40 Setscrew Assortment (11)	4-40 Feststellschrauben-Set (11)	Assortiment de vis de fixation 4-40 (11)	Viti di arresto assortite 4-40 (11)
LOSA6256	4-40 x 1/2 Button Head Cap Screw (6)	4-40 x 1/2 Halbrundschraube (6)	Vis d'assemblage à tête bombée 4-40 x 1/2 po (6)	Vite a testa tonda 4-40 x 1/2 (6)
LOSA6258	2-56 x 5/16" Flathead Screws (24)	2-56 x 5/16 Flachkopfschrauben (24)	Vis à tête plate 2-56 x 5/16 po (24)	Viti a testa piatta 2-56 x 5/16" (24)
LOSA6269	4-40 x 5/16" Flathead Screw (6)	4-40 x 5/16 Flachkopfschraube (6)	Vis à tête plate 4-40 x 5/16 po (6)	Vite a testa piatta 4-40 x 5/16" (6)
LOSA6294	2-56 x 5/16" Cap Screw (6)	2-56 x 5/16 Kopfschraube (6)	Vis d'assemblage 2-56 x 5/16 po (6)	Vite a brugola 2-56 x 5/16" (6)
LOSA6306	4-40 Aluminum Mini-Nuts (10)	4-40 Aluminum Minimuttern (10)	Mini-écrous en aluminium 4-40 (10)	Mini dadi in alluminio 4-40 (10)
LOSA6308	4-40 Steel Locking 1/2 Nuts (10)	4-40 Stahlsicherung 1/2-Mutter (10)	Demi-écrous de blocage en acier 4-40 (10)	Dadi autobloccanti 4-40 1/2" (10)
LOSA6350	#4 and 1/8" Hardened Washers	#4 und 1/8 gehärtete Unterlegscheiben	Rondelles en acier trempé no4 et 1/8 po	Rondelle indurite #4 e 1/8"
LOSA6358	Shim Set	Dichtscheibe-Satz	Jeu de cales	Set spessori

REPLACEMENT PARTS // TEILELISTE // LISTE DES PIÈCES DE RECHANGE // ELENCO DEI RICAMBI

Part #	English	Deutsch	Français	Italiano
LOSA6937	5 x 10mm Shielded Ball Bearing (2)	5 x 10mm abgedichtetes Kugellager (2)	Roulement à billes blindé 5 x 10 mm (2)	Cuscinetti a sfera schermati 5 x 10 mm (2)
LOSA6940	6 x 12mm Sealed Ball Bearing (4)	6 x 12mm abgedichtetes Kugellager (4)	Roulement à billes hermétique 6 x 12 mm (4)	Cuscinetti a sfera sigillati 6 x 12 mm (4)
LOSA6947	5 x 11 x 4mm Rubber Sealed Ball Bearing (4)	5 x 11 x 4 mm gummi-versiegeltes Kugellager (4)	Roulement à billes hermétique en caoutchouc 5 x 11 x 4 mm (4)	Cuscinetti a sfera sigillati in gomma 5 x 11 x 4 mm (4)
LOSA6956	12 x 18 x 4mm Ball Bearing (2)	12 x 18 x 4 mm Kugellager (2)	Roulement à billes 12 x 18 x 4 mm (2)	Cuscinetti a sfera 12 x 18 x 4 mm (2)
LOSB2034	Lower Track Rods	Untere Spurstangen	Barres d'accouplement inférieures	Tiranti inferiori
LOSB2036	Steering Track Rod & Bushings	Lenkspurstange & Buchsen	Bielle de direction et bagues	Tiranti sterzo e boccole
LOSB2037	Upper Track Rods	Obere Spurstangen	Barres d'accouplement supérieures	Tiranti superiori
LOSB2291	Battery Tray	Akkualterung	Support de batterie	Vassoio portabatteria
LOSB2370	Servo Arm & Metal Insert: NCR	Servoarm & Metalleinsatz: NCR	Bras de servo et tubulure métallique : NCR	Squadretta servo e inserto di metallo: NCR
LOSB3012	Center Tranny Case & Supports: NCR	Zentrales Getriebegehäuse und Stützen: NCR	Carter de boîte de vitesses centrale et supports : NCR	Scatola e supporti trasmissione centrale: NCR
LOSB3013	Center Transmission Gear Set	Zentrales Übersetzungsgetriebe-Set	Ensemble boîte de transmission centrale	Set ingranaggio trasmissione centrale
LOSB3014	Center Transmission Shaft/Pin Set	Zentrale Getriebewelle/Stift-Satz	Ensemble arbre/tige de transmission centrale	Set albero/perno trasmissione centrale
LOSB3018	Motor Plate, Black	Motorplatte, Schwarz	Plaque moteur, noir	Piastra motore, nero
LOSB3525	12mm Molded Hex Pins & Lock Nuts (4)	12mm gegossene Sechskantstifte & Sicherungsmuttern (4)	Tiges hexagonales moulées de 12 mm et contre-écrous (4)	Perni esagonali e controdadi stampati 12 mm (4)
LOSB3580	Center CV Drive Shaft	Zentrale CV-Antriebswelle	Arbre de transmission homocinétique central	Albero di trasmissione centrale CV
LOSB3581	Center Drive Shaft Cup Adapter	Zentrale Antriebswelle Telleradapter	Adaptateur coupelle d'arbre de transmission central	Adattatore coppa albero di trasmissione centrale
LOSB3582	Center Drive Shaft CV Yoke, Coupler, Hardware	Zentrales Antriebswelle, CV-Bügel, Kupplung, Hardware	Chape, coupleur, matériel pour arbre de transmission homocinétique central	Yoke, accoppiatore e bulloneria albero di trasmissione centrale CV
LOSB3583	Center CV Drive Shaft Set	Zentrale CV-Antriebswelle-Satz	Ensemble arbre de transmission homocinétique central	Set albero di trasmissione centrale CV
LOSB9996	LED Light Set	LED-Licht-Satz	Ensemble d'éclairage DEL	Set luci LED
SPMSRX200	SRX200 2-CH 2.4 GHz FHSS RX	SRX200 2-CH 2,4 GHz FHSS RX	Récepteur FHSS 2,4 GHz 2 canaux SRX200	SRX200 2-CH 2,4 GHz FHSS RX
SPMSTX200	STX2 2-CH 2.4 GHz FHSS Radio System	STX2 2-CH 2,4 GHz FHSS Funksystem	Système radio FHSS 2,4 GHz 2 canaux SRX2	Sistema radio STX2 2-CH 2,4 GHz FHSS
TLR5902	M3 x 8mm Button Head Screws (10)	M3 x 8 mm Rundkopfschrauben (10)	Vis à tête bombée M3 x 8 mm (10)	Viti a testa tonda M3 x 8 mm (10)
TLR5913	M2.5 x 12mm Button Head Screws (10)	M2,5 x 12mm Rundkopfschrauben (10)	Vis à tête bombée M2,5 x 12 mm (10)	Viti a testa tonda M2,5 x 12 mm (10)
TLR6312	M2.5 x .45 x 5mm Locknut (6)	M2,5 x 0,45 x 5mm Kontermutter (6)	Contre-écrou M2,5 x 0,45 x 5 mm (6)	Controdadi M2,5 x 45 x 5 mm (6)
TLR6352	M3 Washers (10)	M3 Unterlegscheiben (10)	Rondelles M3 (10)	Rondelle M3 (10)
TLR8202	Body Clips, Black (12)	Gehäuseklemmen, schwarz (12)	Clips de carrosserie, noir (12)	Clip carrozzeria, colore nero (12)
TLR255001	M2.5 x 5mm Button Head Screws (10)	M2,5 x 5mm Rundkopfschrauben (10)	Vis à tête bombée M2,5 x 5 mm (10)	Viti a testa tonda M2,5 x 5 mm (10)
TLR336000	4mm Aluminium Serrated Lock Nuts, Black (6)	4mm Aluminium-Rändelmutter, Schwarz (6)	Contre-écrous en aluminium à embase striée 4 mm, noir (6)	Controdado dentato in alluminio 4 mm, nero (6)
TLR235008	M3 x 6mm Flat Head Screws (10)	M3 x 6mm Flachkopfschrauben (10)	Vis à tête plate M3 x 6 mm (10)	Viti a testa piatta M3 x 6 (10)
TLR74006	Silicone Shock Oil, 30 wt, 2 oz	Stoßdämpfer-Silikonöl, 30 wt, 2 oz	Huile de silicone pour amortisseur, 30WT, 2oz	Olio di silicone ammortizzatore, 30 wt, 2 oz
VTR43000	Beadlock Wheel w/Rings (2)	Beadlock-Rad mit Ringen (2)	Roue à verrou de talon avec bagues (2)	Cerchioni Beadlock con anelli (2)
VTR43018	TSL SX Swamper 1.9 Tire w/Insert	TSL SX Swamper 1,9 Reifen mit Einsatz	Pneu 1,9 po TSL SX Swamper avec fond	Ruota TSL SX Swamper 1,9 con inserto

RECOMMENDED PARTS // EMPFOHLENE TEILE // PIÈCES RECOMMANDÉES // PEZZI CONSIGLIATI

Part #	English	Deutsch	Français	Italiano
DYN1070EC	Speedpack 7.2V 3300mAh NiMH 6C Flat: EC3	Speedpack 7,2V 3300mAh NiMH 6C Flach: EC3	Batterie plate NiMH 6C 7,2 V 3300 mAh Speedpack : EC3	Speedpack 7,2 V 3300 mAh NiMH 6C Flat: EC3
DYN9004EC	7.4V 5000mAh 2S 20C LiPo, Hardcase: EC3	7,4V 5000 mA 20C 2S LiPo, Hartschale: EC3	7,4V 5000mA 20C, boîtier rigide avec prise EC3	7,4V 5000 mAh 2S 20C LiPo, Hardcase: EC3
DYNC2000CA	Prophet Sport NiMH 35W AC Charger	Prophet Sport NiMH 35 W AC-Ladegerät	Chargeur CA NiMH 35W Prophet	Caricabatterie Prophet Sport NiMH 35W AC
DYNC2005CA	Prophet Sport LiPo 35W AC Charger	Prophet Sport LiPo 35 W AC-Ladegerät	Chargeur CA LiPo 35W Prophet Sport	Caricabatterie Prophet Sport LiPo 35W AC
DYNC2010CA	Prophet Sport Plus 50W AC/DC Charger	Prophet Sport Plus 50 W Wechsel-/Gleichstrom-Ladegerät	Chargeur CA/CC 50W Prophet Sport Plus	Caricabatterie Prophet Sport Plus 50W AC

OPTIONAL PARTS // OPTIONALE TEILE // PIÈCES OPTIONNELLES // PARTI OPZIONALI

Part #	English	Deutsch	Français	Italiano
DYNC3000	Ultra 100W AC/DC Touch Charger	Ultra 100W AC/DC Touch Ladegerät	Chargeur Ultra AC/DC 100W Touch	Caricabatterie Ultra AC/DC 100W Touch
DYNT0501	Start Up Tool Set	Anfänger-Werkzeugsatz	Set d'outils de démarrage	Set attrezzi
DYN9005EC	7.4V 5000mAh 2S 30C LiPo, Hardcase: EC3	7,4V 5000 mA 30C 2S LiPo, Hartschale: EC3	7,4V 5000mA 30C, boîtier rigide avec prise EC3	Batteria LiPo hardcase 7,4V 5000mAh 2S 30C: EC3
DYNB3802EC	7.4V 5000mAh 2S 50C LiPo, Hardcase: EC3	7,4V 5000 mA 50C 2S LiPo, Hartschale: EC3	7,4V 5000mA 50C, boîtier rigide avec prise EC3	Batteria LiPo hardcase 7,4V 5000mAh 2S 50C: EC3
DYNB3850EC	7.6V HV 4000mAh 2S 50C LiPo Hardcase	7,6V HV 4000 mA 50C 2S LiPo, Hartschale: EC3	7,6V 4000mA 50C, boîtier rigide avec prise EC3	Batteria LiPo hardcase 7,6V 4000mAh 2S 50C: EC3
DYNB3852EC	7.6V HV 5000mAh 2S 50C LiPo Hardcase: EC3	7,6V 5000 mA 50C 2S LiPo, Hartschale: EC3	7,6V 5000mA 50C, boîtier rigide avec prise EC3	Batteria LiPo hardcase 7,6V 5000mAh 2S 50C: EC3
LOSA43005	2.2 Beadlock Wheels, Chrome with Red Rings (2)	2,2 Beadlockfelgen chrom und rote ringe (2)	2,2 Jantes Beadlock chrome avec anneaux rouge (2)	Ruote Beadlock cromo con anelli rosso 2,2 (2)
LOSA3186	12 mm Alumnum 5.7 mm (wide) Hex (4)	12 mm Alumnum 5,7 mm (breit) Hex (4)	12 mm Alumnum 5,7 mm (large) Hex (4)	12 mm Alumnum 5,7 mm (largo) Esagonale (4)
LOSA7682B	Front/Rear Rock Claws 2.2 Tires w/Foam, Blue (2)	Vorne / Hinten Rock Claws 2.2 Reifen w / Foam, Blau (2)	Griffes de roche avant / arrière 2,2 Pneus avec mousse, bleu (2)	Rock Artigli anteriori / posteriori 2,2 Pneumatici w / Foam, Blu (2)

EXPLODED VIEW // EXPLOSIONSZEICHNUNG // VUE ÉCLATÉE DES PIÈCES // VISTA ESPLOSA DELLE PARTI

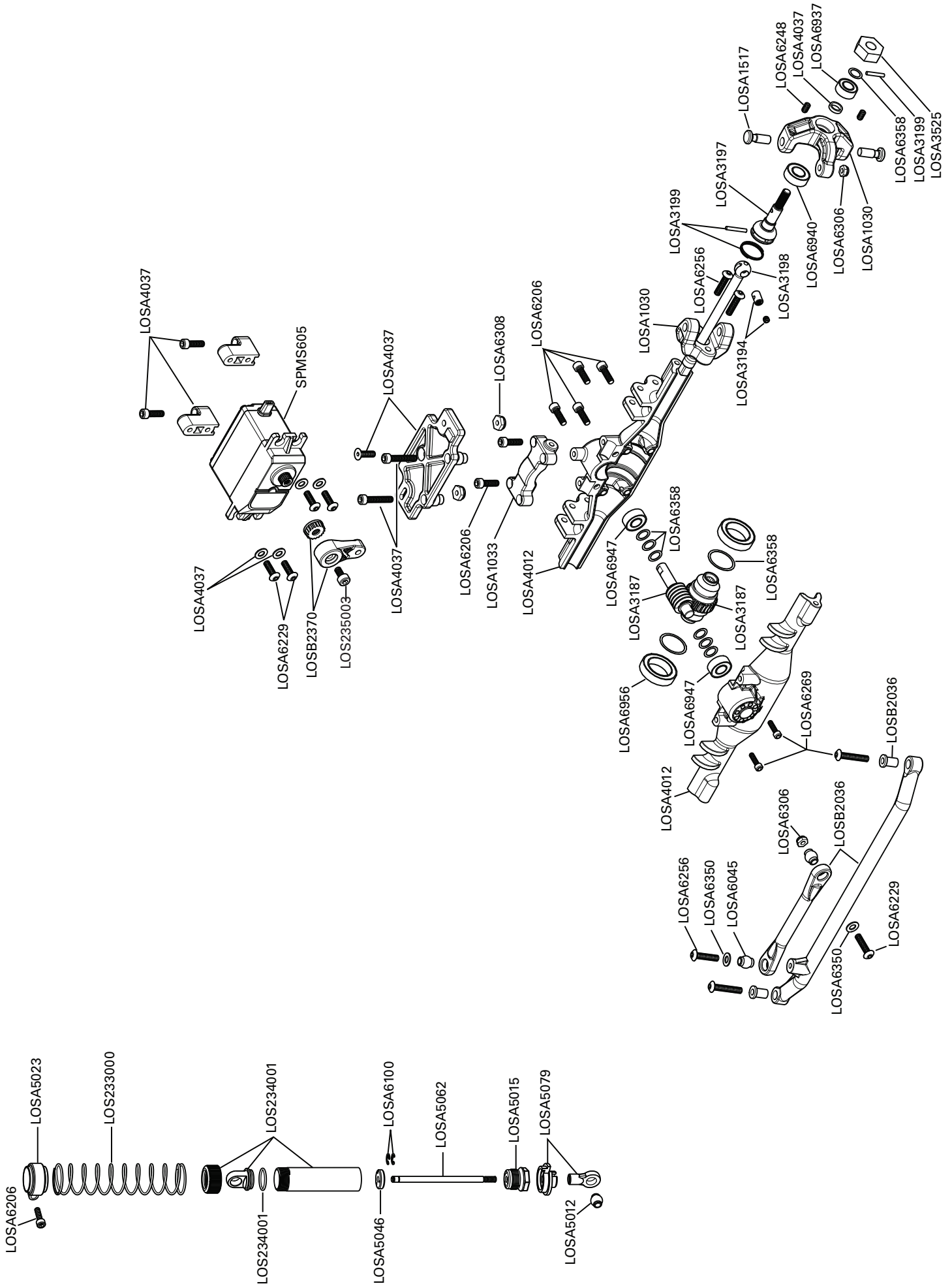

EXPLODED VIEW // EXPLOSIONSZEICHNUNG // VUE ÉCLATÉE DES PIÈCES // VISTA ESPLOSA DELLE PARTI

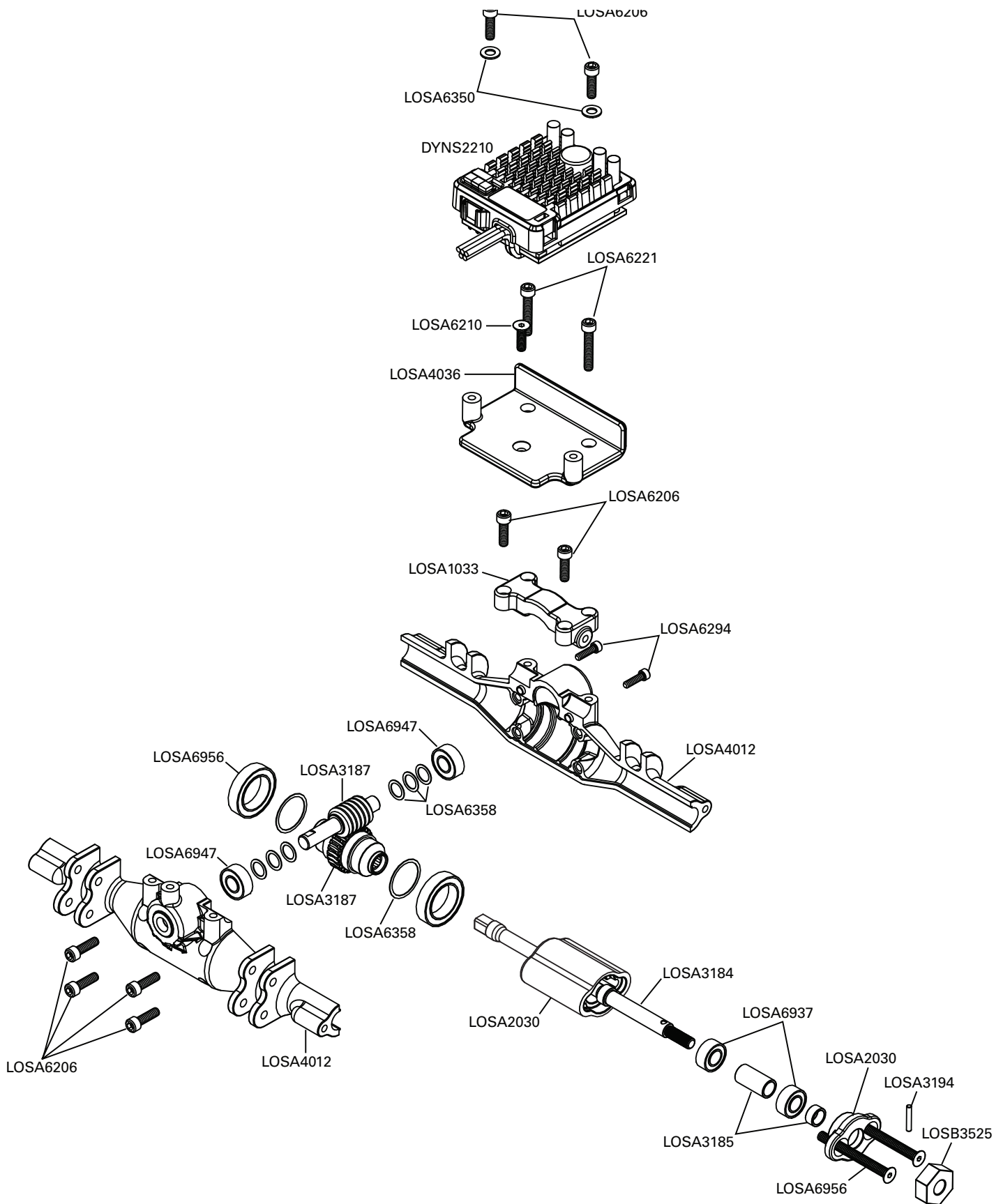

EXPLODED VIEW // EXPLOSIONSZEICHNUNG // VUE ÉCLATÉE DES PIÈCES // VISTA ESPLOSA DELLE PARTI

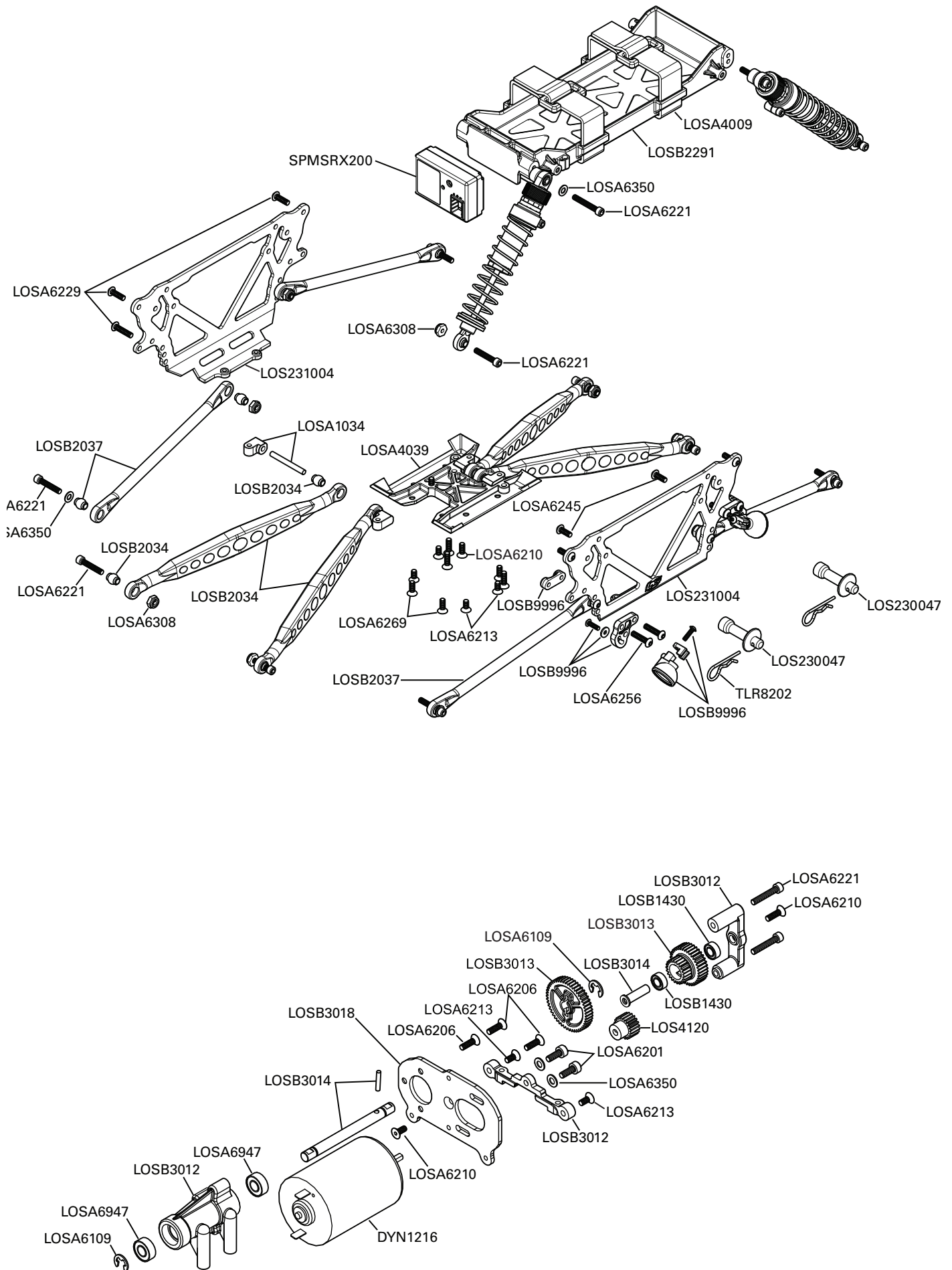



WWW.LOSI.COM

©2018 Horizon Hobby, LLC.

Losi, STX2, DSM, DSM2, DSMR, EC3, Dynamite, Fuze, Prophet and the Horizon Hobby logo are trademarks or registered trademarks of Horizon Hobby, LLC.

The Spektrum trademark is used with permission of Bachmann Industries, Inc.

Created 12/17

55511

LOS03015

